



ES 10 USER MANUAL

EFFICIENCY SERIES ES 10

High Efficiency Power Amplifier
User Manual



A NEW WORLD OF SOUND!®



ES 10 USER MANUAL

Published by:

New Stage Accompany B.V.

Training & Documentation

Anodeweg 4

1627 LJ Hoorn, The Netherlands

Copyright © 1998 by New Stage Accompany B.V.

All rights reserved. No part of this manual may be reproduced or transmitted in any form or by any means, electronically or mechanical, without written permission from New Stage Accompany B.V. , except for the inclusion of brief quotations in a review.

First printing, September 1998

Printed in The Netherlands

This manual is intended to provide information about the Stage Accompany ES 10. Every effort has been made to make this manual complete and as accurate as possible. However no warranty of suitability, purpose, or fitness is implied. The information is provided on an “as-is” basis. New Stage Accompany B.V. shall have neither liability nor responsibility to any person or entity with respect to any loss or damages in connection with or arising from the information contained in this manual.

New Stage Accompany B.V. reserves the right to alter specifications without prior notice.



ES 10 USER MANUAL

Table of Contents

Quick Introduction to the ES 10

Introduction

Connections

Operation

Recommendations

Technical Specifications

Warranty

Overview



Table Of Contents

1	Quick Introduction to the ES 10	1-1
2	Introduction	2-1
3	Connection of the ES 10	3-1
3.1	Mains Power Connection	3-1
3.2	Audio Connections	3-4
3.3	Loudspeaker Connections	3-5
4	Operation	4-1
4.1	Input Attenuators	4-1
4.2	Bridge Mode Switch	4-1
4.3	Ground Lift Switch	4-2
4.4	Indicators	4-2
5	Recommendations for Optimum Use	5-1
6	Technical Specifications	6-1
7	Warranty	7-1
8	Overview	8-1



1 Quick Introduction to the ES 10

Thank you for choosing a Stage Accompany Power Amplifier. Making this choice has guaranteed you many years of troublefree amplification.

If you have to start using the ES 10 straight away and do not have time to read the complete manual, make sure that you at least read the following:

- Ensure that you have a reliable, well earthed power source. The required current for the ES 10 can be found in the table in paragraph 3.1.
- Connect the ES 10 to your signal sources via the <INPUT> connectors. Connect this amplifier to other units via the <LINK> outputs using short signal leads. Connect your single signal source to the channel 1 input if you use the ES 10 in bridge mode.
- Never make connections to the amplifier or to any preceding equipment with the amplifier switched on.

Important

When combining ES 10s with a Stage Accompany Blue Box system, you must take into account that the low-frequency loudspeaker of the Blue Box has an excursion opposite to that of a normal speaker-amplifier combination. The Blue Boxes in combination with the ES 10s have to be switched to inverted phase, or cross cables for ES 10s or Blue Boxes have to be used!

- Switch the ES 10 on using the <POWER ON/OFF> switch.

If you want to use the ES 10 in bridge mode, set the <MODE> switch at the back of the amplifier in the <BRIDGE MODE> position. Connect the speaker system to the <BRIDGE MODE OUTPUT>.

- Select the desired input sensitivity by means of the <INPUT ATTENUATORS>. In bridge mode, always set the input attenuators in the same position.
- Any earth hum that may be present may be solved with the <GROUND LIFT> switch.

The ES 10 is now ready for use.

2 Introduction

The Stage Accompany ES 10 is a dual channel, high efficiency power amplifier and comprises the following components:

- Balanced input stages.
- Two high efficient amplifiers which deliver each 290 Wrms into 8 Ω , 430 Wrms into 4 Ω and 530 Wrms into 2 Ω or 340 W peak into 8 Ω , 540 W peak into 4 Ω , and 710 W peak into 2 Ω .
- Advanced protection circuits.

The audio inputs and link outputs are connected internally without electronics. This is done to prevent any loss of sound quality. With an input impedance of 22 k Ω , it is possible to connect a maximum of 30 ES 10s to a 600 Ω source like the SA 1310 graphic equaliser. If more than 30 units need to be connected to a single source, a separate signal driver must be used.

The ES 10 is protected against the connection of speaker impedances less than 2 Ω or even short circuiting of the output. In these cases the output current is limited but the amplifier keeps working.

The ES 10 has a number of features, including:

- High efficiency class G operation.
- Variable speed DC fan.
- DDC (Dynamic Damping Control).
- EFN circuit (Extended Function Network)
- Soft start to reduce power on inrush current.
- Temperature, DC, HF and short circuit protection.

Class G operation

The power supply of the ES 10 amplifier produces 2 different supply levels. Each channel actually consists of two power amplifiers. One produces the output signal, the other one selects the power supply voltage. This way, the ES 10 uses the low level supply at low output power and the high level supply at high output power which reduces internal dissipation significantly.

DC Fan

The built in DC fan has a continuous variable speed. Its control circuit monitors the temperature of the output devices and the temperature of the power supply. The speed of the fan is calculated out of this information. This system ensures that the fan always runs at optimum speed and thus produces less noise.

DDC

DDC (Dynamic Damping Control) is a special way of measuring the cone movement of a loudspeaker. The voltage induced in the voice coil is sensed and fed back to the amplifier's feedback circuit. Hence, a virtually infinite damping is achieved, which results in an exceptionally tight sound reproduction.

EFN

Through the internal EFN circuit, with plug-in modules, extra functions can be added to the amplifier, like cross-over, high- low- or band-pass filtering, equalization and loudspeaker protection. Special protection boards are available for all Stage Accompany loudspeaker systems. The installation of an EFN module needs to be done by an authorised Stage Accompany service centre.

Soft Start

The soft start circuit is active when the ES 10 is turned on. The mains inrush current, which normally is in excess of 50 A is limited to a safe value. However, take care not to switch on too many ES 10 amplifiers at the same time, or you risk that the main fuses of your distribution may trip.

Temperature, DC, HF and Short Circuit Protection

The amplifier and the loudspeakers are protected against all possible damages.

3 Connections

Only three connections need to be made: mains power, audio input signals, and loudspeaker leads. Do not make any connections to the amplifier or to any preceding equipment with the amplifier switched on

3.1 Mains Power Connection

The ES 10 is internally selectable for 110-120/220-240V 50/60Hz mains voltage. The exact voltages are stated at the rear of the amplifier. Switching between mains voltages has to be done by an authorised Stage Accompany service centre. Connecting to the wrong voltage is dangerous and may damage the amplifier. Always ensure that you use a correctly grounded power supply. If more than one ES 10 is to be used, it is advisable to connect each one

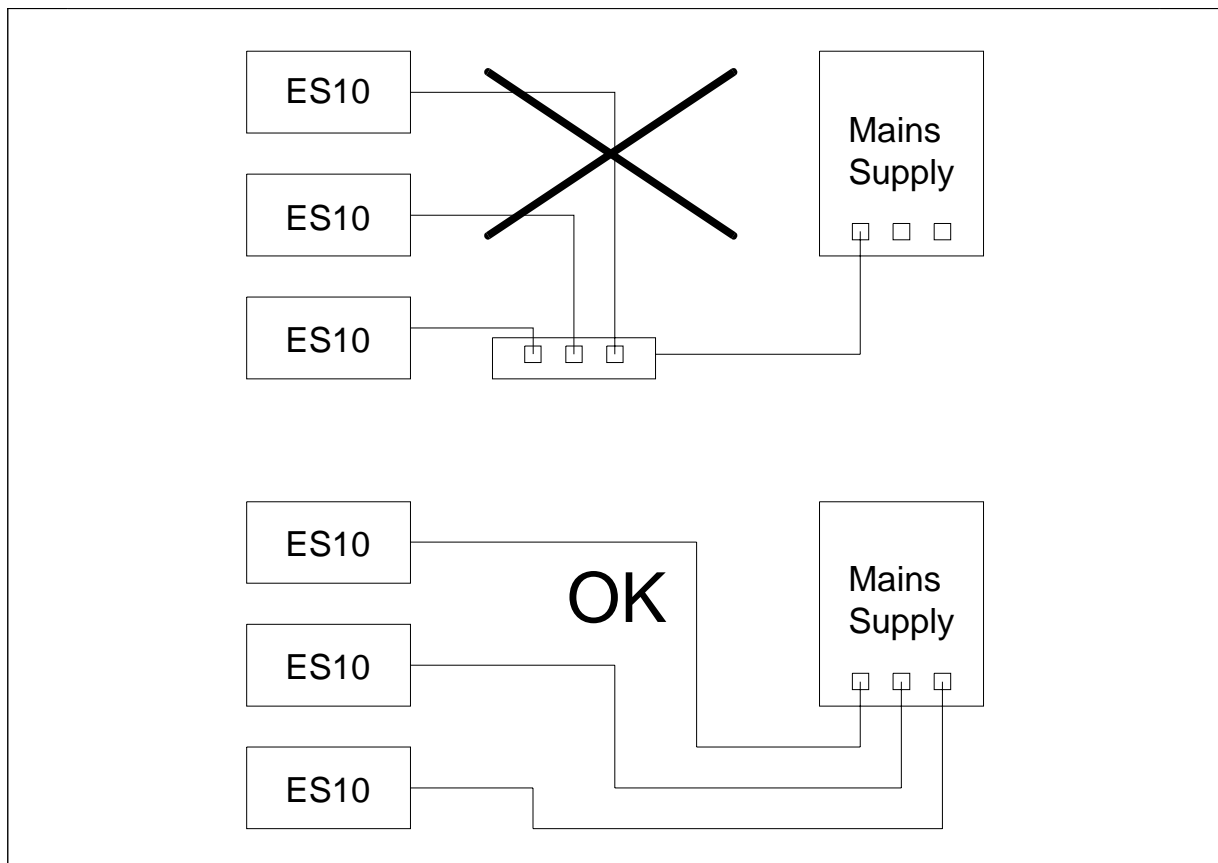

Figure 3-1 ES 10 connections to the mains supply.

separately to the nearest mains supply in stead of connecting several ES 10s using an adapter block (see figure 3-1).



This will prevent unnecessary power loss in the mains cables. If circumstances do not allow this, it is advisable to connect the adapter block directly to the power supply using a short cable and then connect the individual ES 10s to it using longer leads. Although this method is not ideal, it does limit power loss as much as possible.

Ultimately, it is possible to place the adapter block near the ES 10s, but if a great deal of power is required from the unit, the final current provided is far from optimum: loss of current leads to unrecoverable loss of output power and therefore sound pressure.

Warning :

Always disconnect the ES 10 from the power supply before operating on the fuse holders! Replace a blown fuse only with a new one of the same type and value!

Current Table

Below, the current consumption of the ES 10 is tabulated for two selectable mains voltages. The power consumption shown applies to 1/8 of maximum output power pink noise in 2 Ω, which is representative for typical music program with occasional clipping. If your speaker system has an impedance of 4 or 8 Ω you may multiply the currents by 0.5 or 0.25.

No. ES 10s	Mains Voltage (V)	
	110-120	220-240
Current Consumption (A)		
1	6	3
2	12	6
3	18	9
4	24	23
5	30	25
6	36	28
7	42	21
8	48	24
9	54	27

Table 3-1 Current consumption as a function of the mains voltage at 1/8 of maximum output power with pink noise in 2 Ω.

The mains voltage may NOT deviate more than -20 % to +10 % of the nominal value. The proportional mains voltage cable loss may not exceed 10 %. The following formula may be used to calculate the maximum mains cable length in meters for 220-230 V models:

$$\text{Maximum Length (ML)} = \frac{G * 120}{N}$$

The two input variables are:

- N - number of ES 10s supplied through the cable
- G - cable gauge in square millimeters

For 110-120 V models the following formula applies:

$$\text{Maximum Length (ML)} = \frac{G * 30}{N}$$

This means that the cable length is proportional to the cable gauge, while it is inversely proportional to the number of ES 10s supplied through the cable.

On this and the next page, per mains voltage a table is shown with the maximum mains cable length in meters, given the cable gauge in square millimeters and the number of ES 10s supplied through the cable.

115 V		Cable Gauge (mm ²)					
		1.5	2.5	4.0	6.0	10.0	16.0
No. of ES 10s	1	46	75	120	180	300	480
	2	23	38	60	90	150	240
	3	15	25	40	60	100	160
	4	11	19	30	45	75	120
	5	9	15	24	36	60	96
	6	8	13	20	30	50	80
	7	6	11	17	26	43	69
	8	6	9	15	23	38	60
	9	5	8	13	20	33	53
	10	5	8	12	18	30	48

Table 3-2 Maximum cable length as a function of the cable gauge and the number of ES 10s supplied through the cable.

220-240 V		Cable Gauge (mm ²)					
		1.5	2.5	4.0	6.0	10.0	16.0
No. of ES 10s	1	180	300	480	720	1200	1920
	2	90	150	240	360	600	960
	3	60	100	160	240	400	640
	4	23	75	120	180	300	480
	5	36	60	96	144	240	384
	6	30	56	80	120	200	320
	7	26	43	69	103	171	274
	8	23	38	60	90	150	240
	9	20	33	53	80	133	213
	10	18	30	48	72	120	192

Table 3-3 Maximum cable length as a function of the cable gauge and the number of ES 10s supplied through the cable.

3.2 Audio Connections

The XLR connectors (audio in and audio link) of the ES 10 are wired as follows:

Pin 1 = ground

Pin 2 = normal phase (signal+ or “hot”)

Pin 3 = inverted phase (signal- or “cold”)

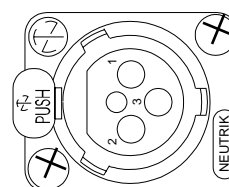

Always use high quality XLR connectors and shielded signal cables. Using the signal link connectors, up to 30 ES 10s can be linked without a problem. If more than 30 ES 10s need to be interconnected, a separate signal driver should be used.

The input stages are electronically balanced. To make optimum use of the balanced input stages even in unbalanced situations, use balanced signal cables and connect pin 3 to pin 1 at the output of the preceding apparatus. If this is not possible, connect pin 3 to pin 1 at the input of the ES 10.

3.3 Loudspeaker Connections

Due to the DDC feature, the ES 10 has 4 output terminals per channel instead of 2. The speakon connector is wired as follows:

Pin 1+ = "hot" or Signal+

Pin 1- = "cold" or Signal-

Pin 2+ = "DDC hot" or DDC+

Pin 2- = "DDC cold" or DDC-

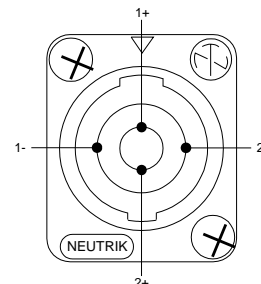

For optimum performance, the amplifier to loudspeaker connections should be made as shown in figure 3-2.

The signal+ and DDC+ (Dynamic Damping Control) terminals are linked together at the

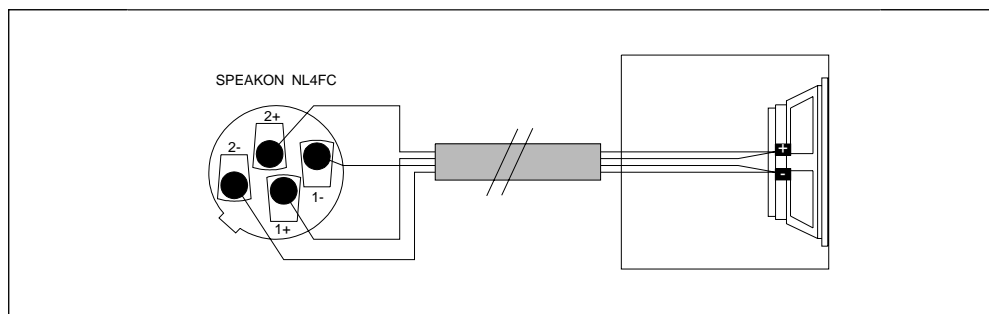

Figure 3-2 ES 10 4-terminal loudspeaker connection.

loudspeaker + terminal. The signal- and DDC- terminals are linked at the loudspeaker - terminal. A maximum damping is obtained with these connections. If your speaker system is not prepared for a four terminal connection, link the DDC and the signal leads at the input of the enclosure (see figure 3-3).

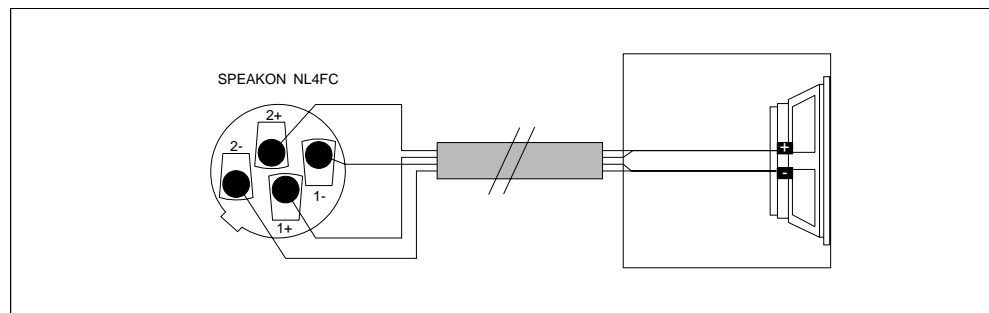

Figure 3-3 ES 10 2-terminal loudspeaker connection

If you don't want to use the DDC feature at all, the DDC and the signal leads should be linked at the amplifier output in the speakon connector (see figure 3-4). The DDC terminals can also be left unconnected but then the performance will be less.

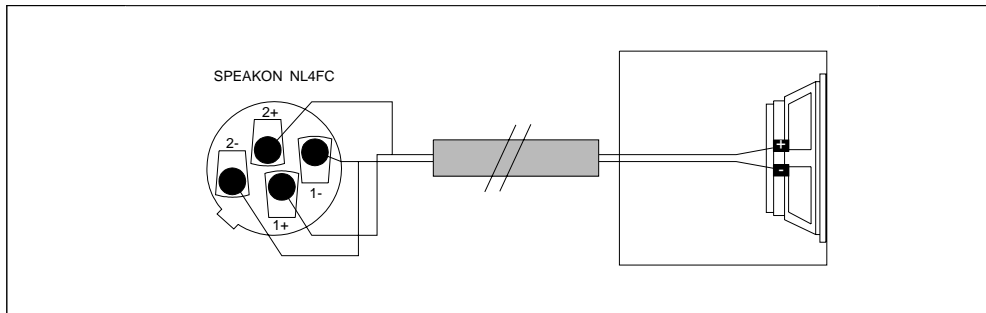

Figure 3-4 ES 10 loudspeaker connection without DDC.

Warning ! Never short-circuit the DDC terminals, and never connect the signal+ output terminal to the DDC- terminal or vice versa (see figure 3-5). Since you are disabling the amplifier's feedback network, signal gain will be almost infinite. The smallest input signal will result in full power output with the possibility of square waves damaging your loudspeakers!

Therefore, check your cables regularly. We also advice you to use special Stage Accompany 4-wire loudspeaker cable: 2 x 3.0 mm² and 2 x 0.75 mm² .

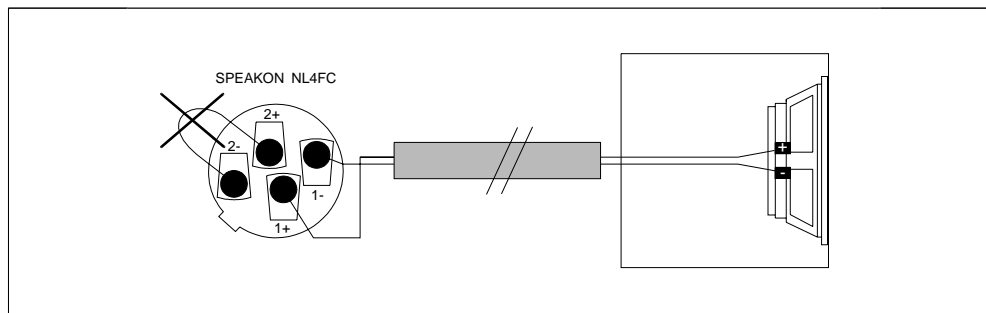

Figure 3-5 Dangerous ES 10 output connection.

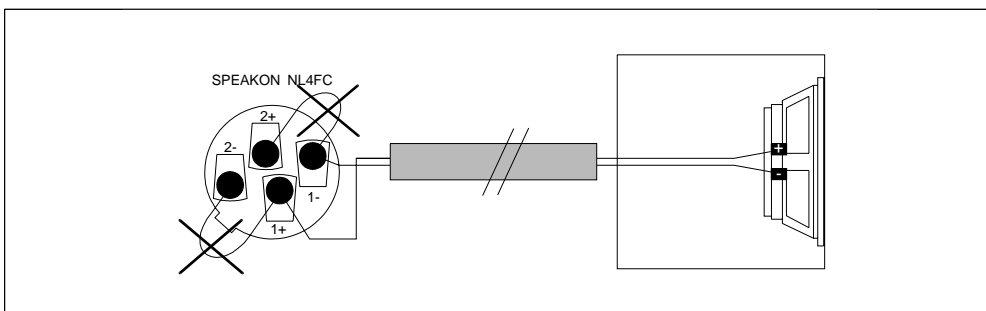

Figure 3-6 Dangerous ES 10 output connection

When more speakers are going to be connected to one amplifier, split the output and DDC leads as soon as possible behind the output terminals of the ES 10 (see figure 3-7 on this and figure 3-8 on the next page).

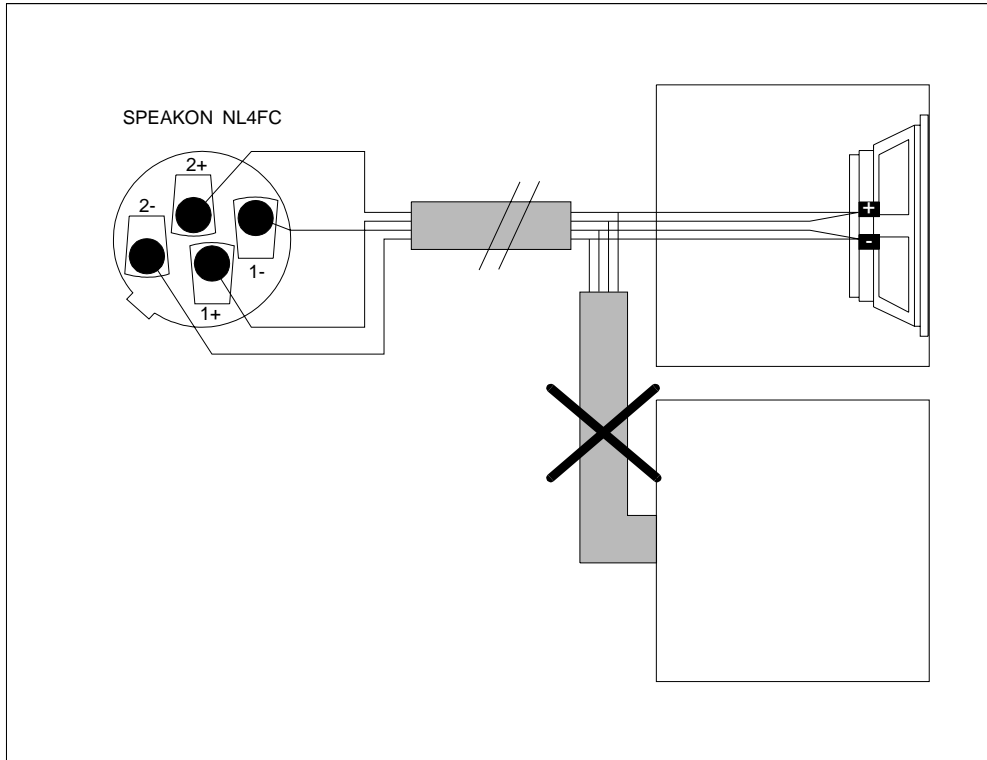

Figure 3-7 Try to avoid this way of connecting several enclosures to the ES 10.

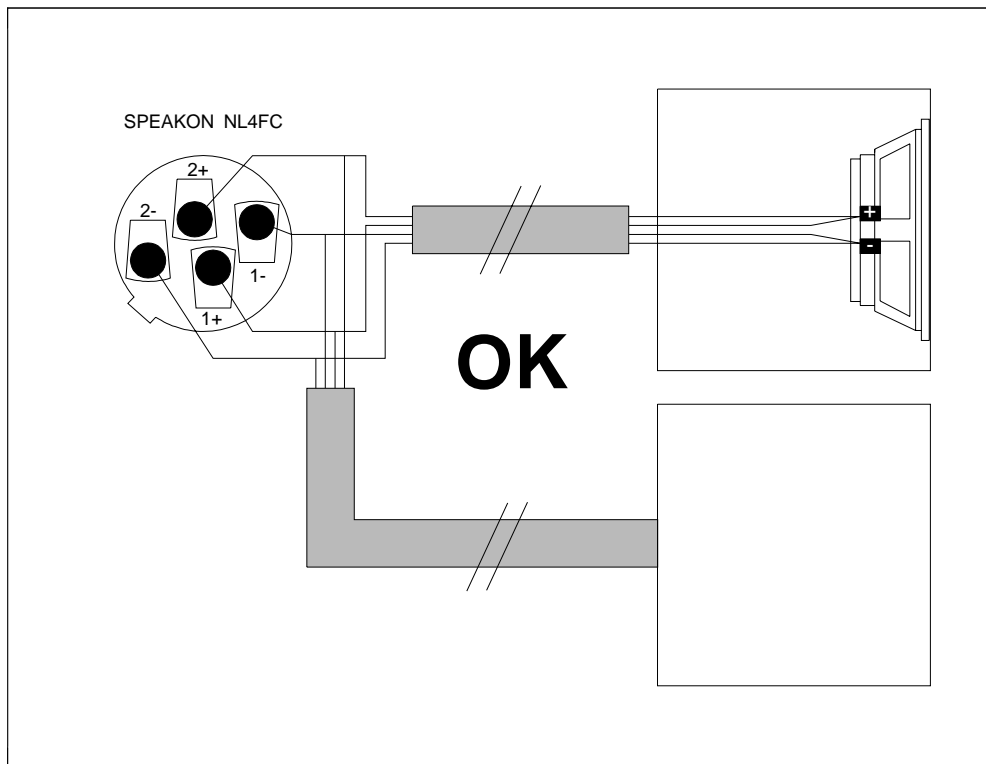

Figure 3-8 Correct way of connecting several enclosures to the ES 10

The amplifier can cope with any load of $2\ \Omega$ or higher. This means that you may connect a maximum of two $4\ \Omega$, four $8\ \Omega$, or eight $16\ \Omega$ loudspeakers per channel in parallel. Linking the loudspeakers from one enclosure to another has two major disadvantages:

1. The loudspeaker cable from the amplifier to the first enclosure conducts the current for all enclosures, which means extra losses.
2. The DDC only works for the first enclosure.

Splitting the leads at the amplifier output terminals solves these problems (see figure 3-8). The DDC system corrects the performance loss due to connectors, loudspeaker cables and so on. However, it cannot prevent loss of power. So only use cables of minimal $2 \times 1.5\ \text{mm}^2$ or more for the loudspeaker leads and $2 \times 0.75\ \text{mm}^2$ for the DDC leads.

For bridge mode operation, connect the speaker to the bridge mode output connector. Its wiring is identical to the other outputs.

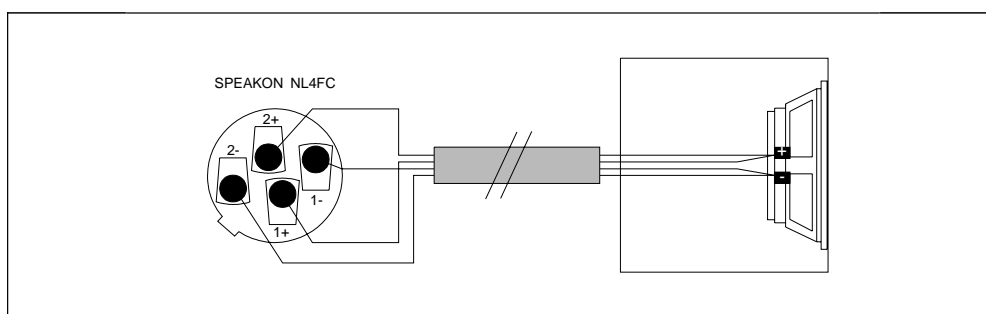

Figure 3-9 ES 10 bridge mode to loudspeaker connections.

An indication of the proportional cable power loss (percentage of the amplifier's total output power) can be calculated using the following formula:

$$\text{Proportional Power Loss} = \frac{100}{1 + \frac{29.4 * G * R}{L}}$$

where the variables represent:

- L - cable length in meters
- G - cable gauge in square millimeters
- R - DC resistance of the loudspeaker(s) in ohms

This formula is based on the DC resistance in stead of the complex impedance of the loudspeaker(s). However, the approximation can be used to get a good impression of the loudspeaker cable power loss. Per loudspeaker impedance a table is shown in tables 3-9 to 3-12 with the proportional power loss, given the loudspeaker cable gauge in square millimeters and the cable length in meters.

16 Ω		Cable Gauge (mm ²)						
		1.5	2.5	3.0	4.0	6.0	10.0	16.0
Cable Length (m)	10	1.4	0.8	0.7	0.5	0.4	0.2	0.1
	20	2.8	1.7	1.4	1.1	0.7	0.4	0.3
	30	4.1	2.5	2.1	1.6	1.1	0.6	0.4
	40	5.4	3.3	2.8	2.1	1.4	0.8	0.5
	50	6.6	4.1	3.4	2.6	1.7	1.1	0.7
	100	12.4	7.8	6.6	5.0	3.4	2.1	1.3

Table 3-4 Proportional power loss as a function of loudspeaker cable gauge and cable length (%).

		Cable Gauge (mm ²)						
		1.5	2.5	3.0	4.0	6.0	10.0	16.0
Cable Length (m)	10	2.8	1.7	1.4	1.1	0.7	0.4	0.3
	20	5.4	3.3	2.8	2.1	1.4	0.8	0.5
	30	7.8	4.9	4.1	3.1	2.1	1.3	0.8
	40	10.2	6.4	5.4	4.1	2.8	1.7	1.1
	50	12.4	7.8	6.6	5.0	3.4	2.1	1.3
	100	22.1	14.5	12.4	9.6	6.6	4.1	2.6

Table 3-5 Proportional power loss as a function of loudspeaker cable gauge and cable length (%).

		Cable Gauge (mm ²)						
		1.5	2.5	3.0	4.0	6.0	10.0	16.0
Cable Length (m)	10	5.4	3.3	2.8	2.1	1.4	0.8	0.5
	20	10.2	6.4	5.4	4.1	2.8	1.7	1.1
	30	14.5	9.3	7.8	6.0	4.1	2.5	1.6
	40	18.5	12.0	10.2	7.8	5.4	3.3	2.1
	50	22.1	14.5	12.4	9.6	6.6	4.1	2.6
	100	36.2	25.4	22.1	17.5	12.4	7.8	5.0

Table 3-6 Proportional power loss as a function of loudspeaker cable gauge and cable length (%).

		Cable Gauge (mm ²)						
		1.5	2.5	3.0	4.0	6.0	10.0	16.0
Cable Length (m)	10	10.2	6.4	5.4	4.1	2.8	1.7	1.1
	20	18.5	12.0	10.2	7.8	5.4	3.3	2.1
	30	25.4	16.4	14.5	11.3	7.8	4.9	3.1
	40	31.2	21.4	18.5	14.5	10.2	6.4	4.1
	50	36.2	25.4	22.1	17.5	12.4	7.8	5.0
	100	53.1	40.5	36.2	29.8	22.1	14.5	9.6

Table 3-7 Proportional power loss as a function of loudspeaker cable gauge and cable length (%).



4 Operation

After connection to the correct mains voltage, the ES 10 can be switched on using the <POWER ON/OFF> switch.

The various functions of the system will now be described one after one.

4.1 Input Attenuators

The input attenuators consist of two 21-detent conductive plastic potentiometers. 11 of the detents are calibrated in dB. The attenuators are used to mute the input signal or to adjust the sensitivity of the ES 10 to other amplifiers. The sensitivity in the 0 dB position is +6 dBu for 35 V output (300 W into 4 Ω). The relative sensitivity to other Stage Accompany amplifiers is:

ES 20:	-3 dB
ES 40:	-6 dB
SA 800:	0 dB
SA 1600	-3 dB
PPA 1200:	-3 dB

Attenuation in the complete counter clockwise position ($-\infty$) is > 90 dB.

Warning:

For bridge mode operation, always set the input attenuators in the same position. If the attenuators are not in the same position, either:

- the amplifier can not deliver its maximum power
- the most attenuated channel can run hot
- at maximum power, the most attenuated channel will limit its output current first, resulting in distortion

4.2 Bridge Mode Switch

The <BRIDGE MODE> switch toggles the amplifier between stereo and bridge mode. In stereo mode, the channel 1 input feeds the channel 1 amplifier, and the channel 2 input feeds the channel 2 amplifier. In bridge mode, the channel 1 input connector feeds both amplifiers. The channel 2 input is not used and is decoupled from the amplifier.

To prevent difficult output connections, the ES 10 is equipped with a unique separate bridge

mode output.

4.3 Ground Lift Switch

If hum is audible after switching on the ES 10, the cause may be incorrect earthing of your sound system. The <GROUND LIFT> switch can be used to “lift” the connection between the system earth and the mains earth. This action alone is often sufficient to eliminate the undesired noise caused by a “bad grounding system”, or “ground loops”.

4.4 Indicators

Each channel of the amplifier is equipped with the following indicators:

- Power: these LEDs will light when the amplifier is switched on.
- Signal present: these LEDs will light when an input level of more than 40 dB under the level that would cause maximum power (+6 dBu) is detected. The signal present LEDs work independently of the settings of the input attenuators.
- Thermal: when the output devices of a channel have reached a temperature of 90 °C, the input of that channel is muted and the thermal LED will light. Both channels work independently, so thermal overload of one channel does not affect the other channel. In case of a continued overload of both channels, it is possible that the power supply runs hot. In that case, both inputs are muted simultaneously.
- DC: the DC LEDs indicate that the output of the amplifier is decoupled from the output connectors. This occurs when the amplifier is switched on and the electronic circuits need time to stabilise. This takes approximately one second. Besides, during normal operation, the amplifier output is decoupled from the output connectors if a dangerous DC voltage is present at the amplifier output.
When the DC LEDs light during normal use, check the following things: Disconnect the speaker system. When the LED(s) switch(es) off, the DDC is probably not properly connected.
When this does not solve the problem, the amplifier is damaged and should be repaired by an authorised Stage Accompany service centre.
- Clip: this LED will light when the output level of the amplifier has reached its limit. The indication is correct for every connected impedance. When the clip LEDs flash frequently, distortion is to be expected.

5 Recommendations for Optimum Use

- Ensure that the quality of the mains supply is good enough and that it can supply the required peak currents. In addition, good earthing is necessary to prevent noise, hum and safety problems. If hum does occur, it can almost always be solved by using the ground lift switch on the back of the amplifier.
- Be sure that the ES 10 is built into a space with sufficient circulation of fresh air. A temperature that is constantly too high leads to switching on and off of the thermal protection and considerably reducing the lifetime of the amplifier.
- When built into a flightcase, ensure yourself that there are sufficient possibilities for the heated air to leave the flightcase. When more ES 10s are built into one flightcase, install an extra fan in the case. Air flow of the ES 10 goes from front to back.
- Do not make connections to the amplifier or to any preceding equipment with the amplifier switched on.
- A faulty fuse must ALWAYS be replaced by a new one of the same type and value! A different fuse can cause permanent damage to the amplifier. All internal fuses are of an automatic type, so they do not need to be replaced. Always disconnect the ES 10 from the power supply before operating on the fuse holder! When a replaced fuse immediately blows again, the amplifier is defect and should be repaired by an authorised Stage Accompany service centre. Do not try to replace the fuse again because you may risk further damage to the amplifier.
- Repairs to the ES 10 should only be carried out by an authorised Stage Accompany service centre. Never dismantle the ES 10 yourself, you may risk damaging vital components: moreover, the guarantee becomes irrevocably invalidated.
- Read this manual carefully. Try out the various functions described in this manual. In this way you will soon become familiar with the many possibilities that the ES 10 offers. It is just as important that your colleagues who will use the ES 10 also read the manual! With a good knowledge of the working of the ES 10, it is possible to fully utilize its superior sound quality in every situation.

GOOD LUCK!



6 Technical Specifications

Input:	1.85 Vrms (+7.5 dBu) (full continuous power into 4 Ω)
Maximum Input Level:	+22 dBu
Input Impedance:	22 kΩ each leg
Common Mode Rejection Ratio (CMRR):	> 70 dB @ 20 Hz - 20 kHz
Frequency Range:	10 Hz - 20 kHz, -0.3 dB @ 50 W into 8 Ω 10 Hz - 120kHz, -3 dB @ 50 W into 8 Ω
Gain:	27 dB (22.4x)
Channel Separation:	75 dB @ 1 kHz, 50 W into 8 Ω 60 dB @ 20 kHz, 50 W into 8 Ω
Total Harmonic Distortion (THD):	< 0.3 % @ 20 Hz - 20 kHz, more than 2 Ω load at all powers, 1 dB below clipping. < 0.01 % @ 1 kHz, 50 W into 8 Ω < 0.1 % @ 20 kHz, 50 W into 8 Ω
Intermodulation Distortion (IMD):	< 0.03 % @ 200 Hz - 10 kHz, < 0.1% @ 10 kHz - 20 kHz F1 = 70 Hz, 4:1, 50 W into 8 Ω
Signal to Noise Ratio:	> 110 dB A-weighted
Slew Rate:	> 40 V/μs @ 8 Ω
Damping (with DDC):	10.000 @ 1 kHz, 10 V across 8 Ω
Output power @ 1 % THD: Continuous Power Delivered:	2 x 290 W RMS into 8 Ω 2 x 430 W RMS into 4 Ω 2 x 530 W RMS into 2 Ω
Peak Power Delivered:	2 x 340 W into 8 Ω 2 x 540 W into 4 Ω 2 x 710 W into 2 Ω

**ES 10 USER MANUAL**

Continuous Bridged Power Delivered:	1 x 580 W RMS into 16 Ω 1 x 860 W RMS into 8 Ω 1 x 1060 W RMS into 4 Ω
Peak Bridged Power Delivered:	1 x 680 W into 16 Ω 1 x 1080 W into 8 Ω 1 x 1420 W into 4 Ω
Mains Supply Voltage:	internally switchable 110-120/220-240 VAC
Power consumption typical	
Idle:	25 VA
1/8 Power, pink noise @ 2 Ω :	700 VA
Weight:	17.7 kg / 39 lb
Housing:	19 in rack mount, 2 HU high, 410 mm (16.1 in) deep behind the mounting surface (without connectors)
Dimensions (h x w x d):	88 x 482 x 415 mm (without connectors and rack handles) (3.5 x 19.0 x 16.3 in)

7 Warranty

New Stage Accompany B.V. warrants to the initial purchaser of each new Stage Accompany product, from the date of purchase by the original purchaser until the end of the warranty period, that the product is free of defects in materials or workmanship.

The warranty period on all Stage Accompany products is five years from the date of the first consumer purchase, with the exception of:

- all electrical products: three years from the date of the first consumer purchase;
- cone assemblies in the loudspeaker and diaphragms of the Ribbon Compact Drivers: one year from the date of the first consumer purchase;
- movable parts, such as castors, locks, handles, hinges, fans etc. one year from the date of the first consumer purchase;
- computers and associated peripherals: six months from the date of the first consumer purchase.

To validate warranty, the purchaser must always keep the original receipt of purchase to establish the date of purchase.

Appeal on warranty will be voided in case:

- of defects caused by influence from the outside, accident, misuse, neglect or influence of water;
- the serial number on the product has been defaced, altered or removed;
- of damage due to shipment;
- of damage resulting from neglecting instructions listed in the user manual;
- of damage caused by incorrect, abnormal handling or abuse during delivery;
- the unit has been repaired (or shows signs of repair) by someone not authorised by New Stage Accompany B.V.;
- the original receipt of purchase cannot be presented whenever warranty service is required;
- the cause of damage is unknown.



Shipment of the product to an authorised Stage Accompany service centre is at the risk and responsibility of the customer. New Stage Accompany B.V. will pay for all labour and material expenses for all repairs covered by the warranty. New Stage Accompany B.V. will not pay for the costs of shipment to the service centre or factory. However, New Stage Accompany B.V. will pay for the costs of return shipment to the customer if repairs are covered by warranty.

Caution:

Warranty work can only be performed at authorised Stage Accompany service centres or at the Stage Accompany factory. Every repair or attempted repair by a non-authorised party will void the warranty.

New Stage Accompany B.V. reserves the right to alter specifications without prior notice.

8 Overview

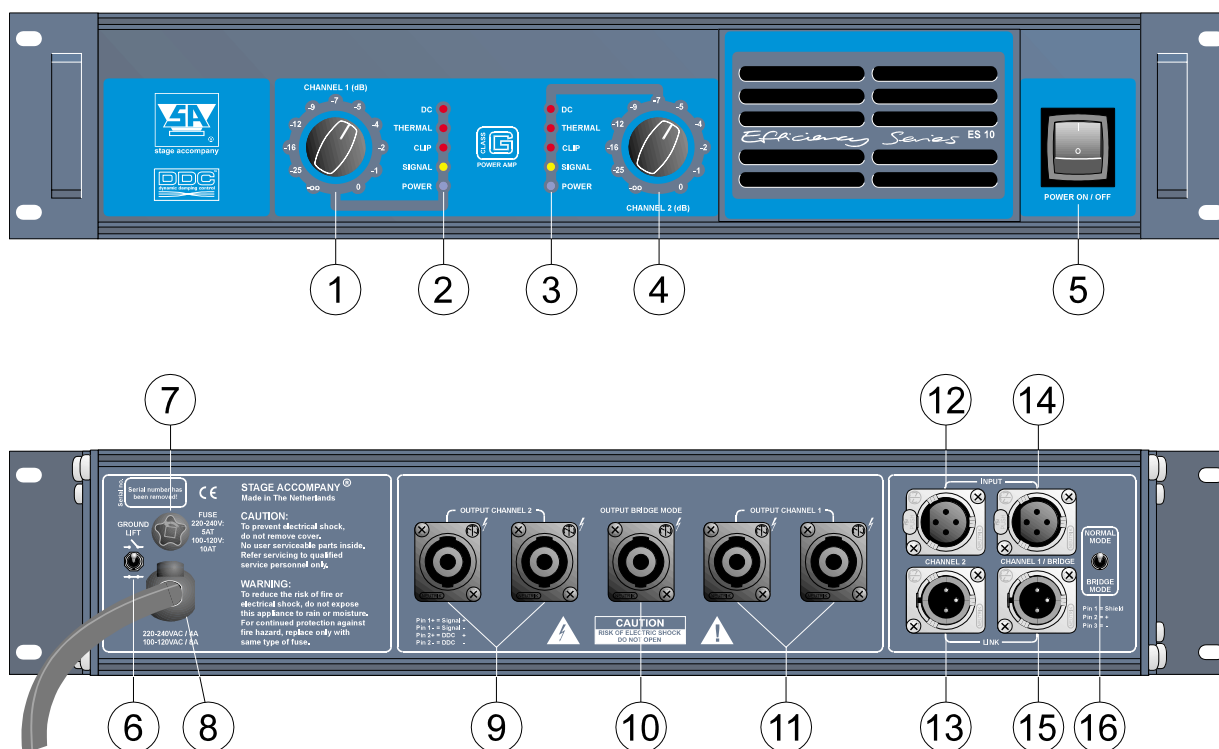

- ① Gain control (Channel 1)
- ② DC, Thermal, Clip, Signal and Power LEDs (Channel 1)
- ③ DC, Thermal, Clip, Signal and Power LEDs (Channel 2)
- ④ Gain control (Channel 2)
- ⑤ Power switch
- ⑥ Ground lift switch
- ⑦ Fuse
- ⑧ AC mains cable
- ⑨ Output (Channel 2)
- ⑩ Output (Bridge mode)
- ⑪ Output (Channel 1)
- ⑫ Input (Channel 2)
- ⑬ Link output (Channel 2)
- ⑭ Input (Channel 1 or bridge mode)
- ⑮ Link output (Channel 2)
- ⑯ Bridge mode switch