



stage accompany

Technical specifications B 30 & B 30S



Placement

The B 30(S) can be placed on the floor. The B 30S, with the Uni-Rig™ flying hardware, can also be flown. Please note that bass-response may vary with the position of the cabinet, through “acoustic coupling”! (floor, ceiling and wall reflections).

Connection

The B 30(S) has one 8-pole Speakon connector and two 4-pole Speakon connectors. The 4-pole Speakon connectors “input” and “link” are used for connection and for linking of other bass cabinets (Caution: When linking, make sure nominal impedance stays within amplifier specification!).

The 8-pole Speakon connector can be used in combination with a Stage Accompany Performer soundsystem.

B 30(S)

In this documentation you will find information about:

- Placement
- Connection
- Maintenance
- Options
- Flying system
- Dynamic Damping Control™
- Recommendation
- Technical specifications

Maintenance

Maintenance on the B 30(S), especially on the drivers is best left to official Stage Accompany service personnel. However, cleaning of the housing can easily be done by yourself with a damp, non fluffing cloth.

Options

On the B 30 the Uni-Rig™ “flying-system” can be ordered as option (this is standard on B 30S). The B 30 and B 30S are standard finished in blue or black. The standard version (B 30) is also available in any possible RAL color (Multi Color Option™).

Flying system

The B 30S is standard equipped with the Uni-Rig™ flying system. The accompanying “fly-ware” can be ordered at your local Stage Shop or dealer. The Uni-Rig™ is available as option on the B 30.

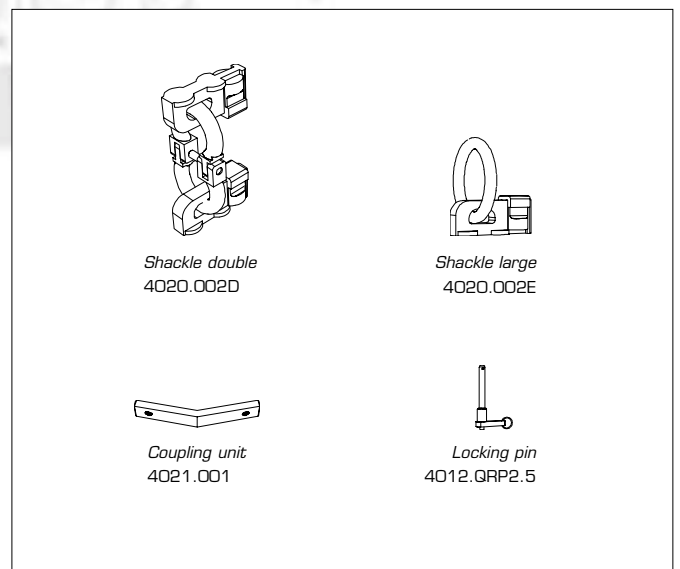
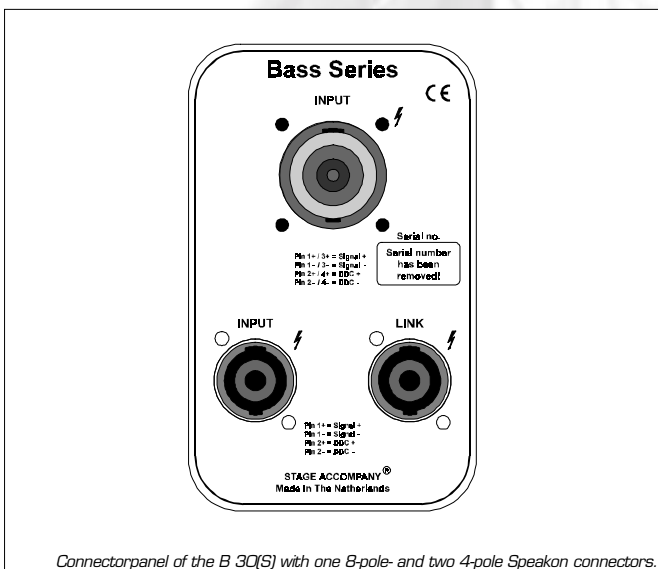

Dynamic Damping Control DDC™

For absolute top quality sound reproduction, the B 30(S) is completely pre wired for Dynamic Damping Control™. The DDC™ system is based on 2 loudspeaker wires that return from the speaker to the (SA) amplifier. Through these "sense wires" the amplifier can compensate the speaker cable and connector resistance, ensuring maximum control over the speaker cone movement.

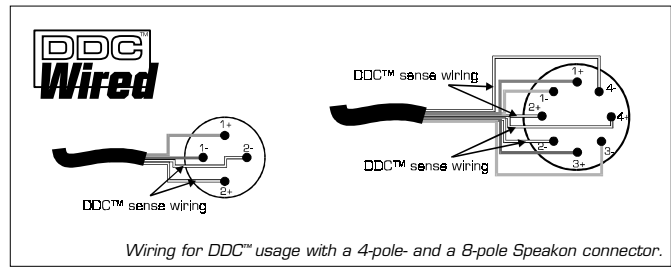

Recommendation

To use the B 30(S) we recommend the ES 20 power amplifier. This amplifier is standard equipped with DDC™, resulting in a virtually infinite amplifier damping factor at the speaker terminals. To use the DDC™ system with an ES 20 amplifier, use Stage Accompany 4-pole LW Speakon cable (note: use the 8-pole LW Speakon cable for Performer PR-2 and PR-3). The ES 20 's Extended Function Network (EFN™) module can provide suitable filtering within the amplifier.

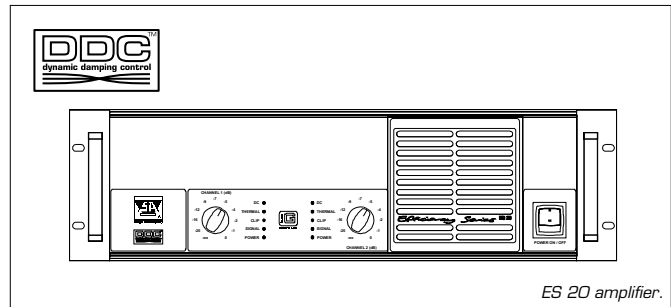

Technical specifications

- Frequency response : 45 Hz - 100 Hz (+/- 3dB)
- Drivers : 2 x SA 1513 LF driver
- Nominal impedance : 4 Ω
- Sensitivity @ 1W/1m : 99 dB
- Max. RMS power : 800 W
- Max. Peak power : 2000 W
- SPL program/peak (dB) : 128/132
- Dispersion (100 Hz H x V) : Omni
- Color : Blue, black, other colors on request
- Front : Expanded metal grille + acoustic transparent cloth
- Connectors : 1 x 8, 2 x 4 pole Speakon; 2 x Input, 1 x Link
- Physical dimensions (h x w x d) : B 30 1158 x 516 x 450 mm (45.6 x 20.3 x 17.7 in.)
B 30S 1163 x 521 x 455 mm (45.8 x 20.5 x 17.9 in.)
- Weight : B 30 52 kg (114 lb)
B 30S 67 kg (147 lb)

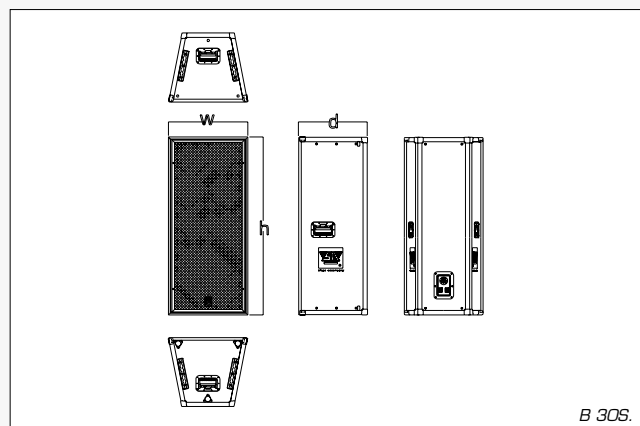
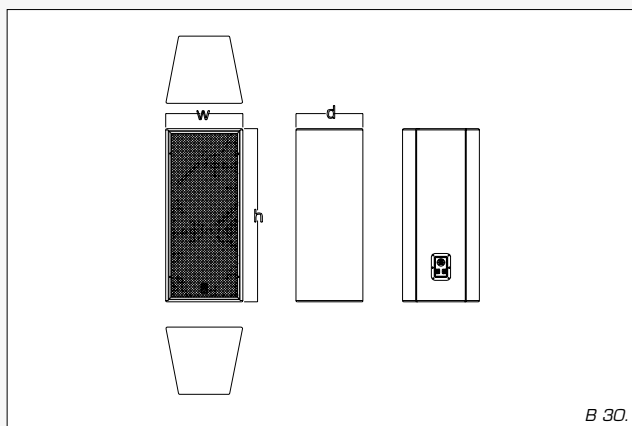

Stage Accompany
Anodeweg 4
1627 LJ HOORN
The Netherlands
Tel: +31 (0)229 282930
Fax: + 31 (0)229 282920
E-mail: info@StageAccompany.com

© Copyright 2001 Stage Accompany.

The information in this document is continually being developed. Whilst every effort has been made to make it as accurate as possible, no warranty of accuracy is made or implied by the makers. Stage Accompany shall have neither liability, nor responsibility to any person or entity with respect to loss or damages in connection with or arising from the information contained in this document.

www.StageAccompany.com

A NEW WORLD OF SOUND!®