

Module LEDs

The module has several LEDs included to indicate status. Function is described below:

HDMI and REF Present LEDs

- = Valid signal connected / converted
- = (out) Signal not valid or missing (or if HDMI has HDCP protection)

Audio Present LED

- = Both external audio input channels are present
- = Only one of the audio input channels is present
- = (out) no audio present

Power / Status LED

- = Power OK and no internal programmed settings are present
- = Power OK and some programmed settings are active*
- = One or more of module switch settings have been overwritten with the yelloGUI application. (Operation of any local switch will change LED status back to Yellow or Green. Note: The module can be factory reset to "Green" using a paperclip in the reset hole.)
- = (out) Power not present

* Some additional internal settings have been made using the yelloGUI and the LED indicates this by turning yellow. The module can be reset to factory default using the yelloGUI application, or by using the internal reset switch on the side of the module, which can be accessed through a hole with a paperclip (or similar)

USB Port / Firmware Updates / yelloGUI

The USB interface on the module is used for firmware updates and for control of the module using the yelloGUI software application. To update a yellobrik, power it and connect it to the PC or Mac running the yelloGUI software with the provided USB cable. The yelloGUI software will indicate if a new firmware is available for the connected module and will guide you through the update process. Firmware updates are always free of charge.

For more information and to download the yelloGUI application please goto: <http://yellogui.lynx-technik.com>

Power Lead Strain Relief

The module has a small hole in the case located above the power connection. To prevent the power lead being accidentally pulled out, use the supplied tie-wrap and secure the lead as shown opposite.

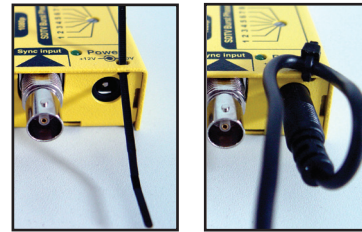

HDMI is connected but no SDI output ? - Common Causes

When two HDMI devices are connected together the EDID communication protocol automatically determines the highest resolution both devices support and configures the HDMI link to that resolution. As the CHD 1812 supports video formats up to 1080p/60Hz the SDI output will typically default to 1080p/60 (3Gbit/s SDI) which if used in a standard 1.5GHz or 270Mbit SDI environment will not display an image. If 1.5Gbit or 270Mbit SDI output is needed, then the HDMI source device should be manually set to output the desired video resolution. Alternatively, it is possible to use the yelloGUI application to force the CHD 1812 into the desired video format. (As we do not have an internal scaler, this is done by limiting the formats reported over EDID so the sending device changes its HDMI resolution)

The HDMI content may have HDCP copy protection, in which case the HDMI present LED will be OUT and the module will block the conversion and provide a black SDI output.

Note: A lot of playback consumer devices impose hardware HDCP copy protection even if the source media is not copy protected. Please verify the operation of the yellobrik module on a HDMI source which is known not to have HDCP copy protection (e.g. most HDMI cameras) before contacting technical support.

Still Having Problems?

Please visit the support center on our website and browse or search the knowledge base, or open a support ticket with your specific questions

www.lynx-technik.com > Support > Tech.Support

yellobrik®

Quick Reference

CHD 1812

HDMI to SDI Converter + Frame Sync.

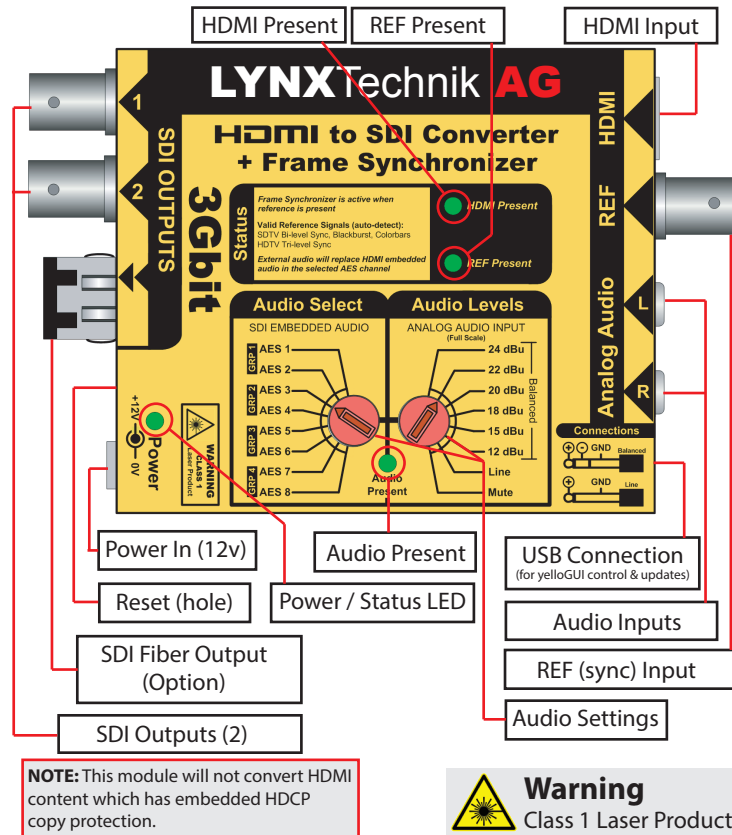

Connections and Adjustments

All connections and adjustments are clearly indicated on the module and self explanatory. Settings can be changed with the module powered on or off. The fiber SDI output is optional and can be added at any time if needed using the socket provided (plug in SFP module).

Basic Operation

The CHD 1812 will auto-detect the connected HDMI input and the HDMI Present LED will illuminate when a valid signal is detected. The HDMI is converted to an SDI signal in its native resolution (no scaling). Two identical electrical SDI outputs (not dual link) are provided as well as an optional fiber SDI output. Any audio present on the HDMI signal will be automatically embedded into the SDI outputs.

Frame Synchronizer

The CHD 1812 includes an internal frame synchronizer which can synchronize the converted HDMI signal to studio reference. (With no reference connected the synchronizer is bypassed). When a valid reference signal is detected the REF Present LED will illuminate and both the video and audio signals are synchronized to the connected reference signal. Frame Sync timing is adjustable using the **yelloGUI** software application. (Only available when reference is connected) The frame synchronizer is fully cross lock compatible meaning it can cross lock between different standards. If the frequency of the reference and HDMI inputs are different the module will perform a simple frame rate conversion by dropping or adding frames.

Audio

The CHD 1812 has two external analog audio inputs (stereo) which can be embedded into a selected AES channel on the SDI outputs. When audio is present the Audio Present LED is illuminated. The analog inputs can be balanced (professional) or unbalanced (line, or consumer). Use the "Audio Levels" rotary switch to select the correct audio level for the audio input. Full scale level for balanced and Line level for consumer inputs. 1/4 inch jack plug to RCA plug adapters are provided for line level consumer audio inputs.

Audio Embedding

Up to 8 channels of audio present on the HDMI input are automatically embedded into the SDI outputs (AES channels 1, 2, 3, 4). If an external audio input is connected then the audio can be inserted into any of the 8 available AES channels of the SDI outputs. The channel is selected using the "Audio Select" rotary switch.

Note: One AES channel = two channels of audio (left and right)

The HDMI audio is not modified or decoded. If encoded audio is present such as Dolby Digital then this encoded stream will be embedded (transparently) into the SDI output. The module automatically disables the sample rate converters if encoded audio is detected. However, if the Frame Synchronizer is active (Reference connected) then encoded audio streams may be repeatedly disturbed or corrupted. (Note: PCM audio content will always be free from disturbances).

NOTE: External audio will overwrite any audio present on the HDMI input if AES channel 1, 2, 3, 4 is selected.

Fiber Output (Optional)

A SDI fiber output is provided via a removable SFP fiber stick. This can be a standard SDI Transmitter (1310nm) or if needed CWDM versions are also available (18 wavelength choices). Please contact LYNX Technik for more details on the fiber options compatible with this module.

HDCP Copy Protection

The CHD 1812 **WILL NOT** convert any HDCP encrypted content. If a HDMI source is connected and the "HDMI present" is **OUT** then the HDMI content is most likely protected with HDCP.

yelloGUI Software Tool

The CHD 1812 is fully compatible with the yelloGUI software application. This provides access to a variety of additional internal settings and features. (Including setting 3D conversion mode, setting frame sync delay and audio configuration)



yellobrik®

Technical Specifications

HDMI Input	3D compatible input using type A connector For a detailed list of supported formats please refer to the article in our knowledge base (www.lynx-technik.com > support > tech.support)
	Up to 8 channels embedded audio in HDMI is passed transparently or replaced with external analog audio input
Reference Input	SDTV: Analog 525 or 625 bi-level sync, black burst or colorbars HDTV: All tri-level sync standards (exceptions 1080p 50/59.94/60Hz) Cross lock compatible. SMPTE 274M, SMPTE 296M
	SMPTE 274M, SMPTE 296M - 75 Ohm BNC connector
Frame Synchronizer	Functional if valid reference is detected, otherwise operates in free run (asynchronous) mode. External audio and HDMI input are frequency locked to external reference, fully cross lock compatible across standards.
SDI Outputs	2 x SDI video, 75 Ohm BNC. (both have the same signal - NOT dual link) SMPTE 424M, SMPTE 292M, SMPTE 259M 3G Level A & B-DL & B-DS according to SMPTE ST 425-1 and ST 425-2 (3D) with image formats 1280 x 720 and 1920 x 1080 For a detailed list of supported formats please refer to the article in our knowledge base (www.lynx-technik.com > support > tech.support)
	Electrical Return Loss: >15dB from 5MHz to 1.5GHz, >10dB from 1.5GHz to 3GHz
Audio Inputs	Left and right analog audio using 1/4 inch jack plugs
	10k Ohm differential balanced input mode with 24,22,20,18,15,12 dBu full scale (selectable)
	Unbalanced mode with (line level) at -10 dBV (1/4 inch Jack Plug to RCA connection adapters supplied)
	Selectable AES channel for audio embedding (1 through 8) (Overwrites any HDMI embedded audio present in selected channel)
	Frequency response: <+/- 0.2dB 20Hz to 20KHz
	48KHz A/D sample rate (free run or frequency locked to ref input)
Power	+12VDC @ 4.7W nominal - (supports 10 - 14VDC input range)

We are constantly adding additional yellobrik modules.
Please visit our website for the latest product updates.

www.lynx-technik.com

LYNXTechnik **AG** | www.lynx-technik.com