

DL1

User Manual

© High End Systems, Inc. 2004, All Rights Reserved

Information and specifications in this document are subject to change without notice. High End Systems, Inc. assumes no responsibility or liability for any errors or inaccuracies that may appear in this manual.

Trademarks used in this text: High End Systems, WholeHog III, Catalyst, the Catalyst Logo, Dataflash, Intellebeam, and LithoPatterns are registered trademarks; and TalkBack, the High End Systems globe logo and the Hog logo are trademarks of High End Systems, Inc. or High End Systems Europe Ltd. Belden is a registered trademark of Belden, Inc. Mac OS is a trademark of Apple Computer, Inc. registered in the U.S. and in other countries.

Other trademarks and trade names may be used in this document to refer to either the entities claiming the marks and names or their products. High End Systems disclaims any proprietary interest in trademarks and trade names owned by others.

HIGH END SYSTEMS[®]



DL1 User Manual
P/N 60600228 Version 6.0
Printed in the USA
November 2005

Contacting High End Systems®

US and the Americas

Sales Department: High End Systems, Inc.
2105 Gracy Farms Lane
Austin, TX 78758 USA
voice: 512.836.2242
fax: 512.837.5290

Customer Service: High End Systems, Inc.
2105 Gracy Farms Lane
Austin, TX 78758 USA
voice: 800.890.8989
24-hour fax: 512.834.9195
24-hour voice mail: 512.837.3063 or 800.890.8989

World Wide Web: <http://www.highend.com>

Declaration of Conformity

according to ISO/IEC Guide 22 and EN45104

Manufacturer's name: High End Systems, Inc.

Distributor's name: High End Systems, Inc.

Distributor's address: 2105 Gracy Farms Lane
Austin, Texas 78758 USA

Declares that the product

Product Name: DL.1

Product Number: All

Product Options: All

conforms to the following EEC directives:

73/23/EEC, as amended by 93/68/EEC

89/336/EEC, as amended by 92/31/EEC and 93/68/EEC

Equipment referred to in this declaration of conformity was first manufactured in compliance with the following standards in 2003:

Safety: EN60950:2000

EMC: EN55022: 1998: Class A ITE

EN61000-3-2

EN61000-3-3

EN55024:1998

EN61000-4-2: Level 3, Class 2

EN61000-4-3: 1995 Level 2 (3V/m)

EN61000-4-4: 1995 Level 2 (1/.5kV)

EN61000-4-5: 1995 Level 3 (2/1kV)

EN61000-4-6: 1965 Level 2 (3Vrms)

EN61000-4-11:1994



USA, Thursday, November 17, 2005

Kenneth Stuart Hansen, Compliance Engineer

Product Modification Warning

High End Systems products are designed and manufactured to meet the requirements of United States and International safety regulations. Modifications to the product could affect safety and render the product non-compliant to relevant safety standards.

Mise En Garde Contre La Modification Du Produit. Les produits High End Systems sont conçus et fabriqués conformément aux exigences des règlements internationaux de sécurité. Toute modification du produit peut entraîner sa non conformité aux normes de sécurité en vigueur.

Produktmodifikationswarnung. Design und Herstellung von High End Systems entsprechen den Anforderungen der U.S. Amerikanischen und internationalen Sicherheitsvorschriften. Abänderungen dieses Produktes können dessen Sicherheit beeinträchtigen und unter Umständen gegen die diesbezüglichen Sicherheitsnormen verstoßen.

Avvertenza Sulla Modifica Del Prodotto. I prodotti di High End Systems sono stati progettati e fabbricati per soddisfare i requisiti delle normative di sicurezza statunitensi ed internazionali. Qualsiasi modifica al prodotto potrebbe pregiudicare la sicurezza e rendere il prodotto non conforme agli standard di sicurezza pertinenti.

Advertencia De Modificación Del Producto. Los productos de High End Systems están diseñados y fabricados para cumplir los requisitos de las reglamentaciones de seguridad de los Estados Unidos e internacionales. Las modificaciones al producto podrían afectar la seguridad y dejar al producto fuera de conformidad con las normas de seguridad relevantes.

FCC Information

This equipment has been tested and found to comply with the limits for a Class A digital device, pursuant to part 15 of the FCC rules. These limits are designed to provide reasonable protection against harmful interference when the equipment is operated in a commercial environment. This equipment generates, uses, and can radiate radio frequency energy and, if not installed and used in accordance with the instruction manual, may cause harmful interference to radio communications. Operation of this equipment in a residential area is likely to cause harmful interference, in which case the user will be required to correct the interference at his own expense.

Important Safety Information

Instructions pertaining to continued protection against fire, electric shock, and injury to persons are found in Appendix A. Please read all instructions prior to assembling, mounting, and operating this equipment.

Important: Informations De Sécurité. Les instructions se rapportant à la protection permanente contre les incendies, l'électrocution, excessif et aux blessures corporelles se trouvent dans l'Annexe A. Veuillez lire toutes les instructions avant d'assembler, de monter ou d'utiliser cet équipement.

Wichtige Sicherheitshinweise. Sicherheitsanleitungen zum Schutz gegen Feuer, elektrischen Schlag, und Verletzung von Personen finden Sie in Anhang A. Vor der Montage, dem Zusammenbau und der Inbetriebnahme dieses Geräts alle Anleitungen sorgfältig durchlesen.

Informazioni Importanti Di Sicurezza. Le istruzioni sulla protezione da incendi, folgorazione, e infortuni sono contenute nell'appendice A. Si prega di leggere tutte le istruzioni prima di assemblare, montare e azionare l'apparecchiatura.

Informacion Importante De Seguridad. En el Apéndice A se encuentran instrucciones sobre protección continua contra incendios, descarga eléctrica, y lesiones personales. Lea, por favor, todas las instrucciones antes del ensamblaje, montaje y operación de este equipo.

Symbols

The following international caution and warning symbols appear in margins throughout this manual to highlight messages.



Caution: This symbol appears adjacent to Caution messages. Not heeding these messages could result in personal injury and/or damage to equipment.



Warning: This symbol appears adjacent to high voltage warning messages. Not heeding these messages could result in serious personal injury.



Minimum focus distance to non-flammable surface. In this case, 1 meter .



Do not mount on a flammable surface.

Equipment surfaces may reach temperatures up to 130° C (266° F). Allow the fixture to cool before handling.

Patents

This product may use one or more of the following patents:

US 4,392,187; US 4,602,321; US 4,688,161; US 4,701,833; US 4,709,311; US 4,779,176; US 4,800,474; US 4,962,687; US 4,972,306; US 4,980,806; US 5,010,459; US 5,031,078; US 5,073,847; US 5,078,039; US 5,186,536; US 5,209,560; US 5,278,742; US 5,282,121; US 5,307,295; US 5,329,431; US 5,331,822; US 5,367,444; US 5,402,326; US 5,430,629; US 5,432,691; US 5,454,477; US 5,455,748; US 5,506,762; US 5,515,254; US 5,537,303; US 5,545,951; US 5,580,164; US 5,590,954; US 5,590,955; US 5,640,061; US 5,647,662; US 5,665,305; US 5,691,886; US 5,728,994; US 5,758,955; US 5,758,956; US 5,769,527; US 5,774,273; US 5,798,619; US 5,806,951; US 5,823,661; US 5,825,548; US 5,828,485; US 5,829,868; US 5,857,768; US 5,882,107; US 5,934,794; US 5,940,204; US 5,945,786; US 5,953,152; US 5,980,066; US 6,048,080; US 6,327,103; US 6,048,081; US 6,057,958; US 6,054,816; US 6,126,288; US 6,142,652; US 6,142,653; US 6,172,822; US 6,188,933; US 6,208,087; US 6,219,093; US 6,220,730; US 6,241,366; US 6,249,091; US 6,255,787; US 6,256,136; US 6,278,542; US 6,278,545; US 6,288,828; US 6,327,103; US 6,331,756; US 6,346,783; US 6,421,165; US 6,430,934; US 6,459,217; US 6,466,357; US 6,502,961; US 6,545,586; US 6,600,270; US 6,635,999; US 6,664,745; US 6,693,392; US 6,719,433; US 6,783,251; US 6,812,653; US 6,866,390; US 6,866,402; US 6,866,451; US 6,869,193; US 6,570,348; US 6,575,577; US 6,605,907; US 6,621,239; US 6,8691,239; US 6,930,456; US 6,955,435; US D347,113; US D350,408; US D359,574; US D360,404; US D365,165; US D366,712; US D370,080; US D372,550; US D377,338; US D381,740; US D409,771; EP 0662275; EP 0767398; DE 621495; DE 655144; DE 797503; EP 0475082; GB 2 043 769 B; GB 2 055 842 B; GB 2 283 808 B; GB 2 290 134 B; GB 2 291 814 B; GB 2 292 530 B; GB 2 292 896 B; GB 2 294 909 B; GB 2 295 058 B; GB 2 303 203 B; GB 2 306 887 B; GB 2 307 036 B; GB 2 316 477 B; MR0862-1996; M9,604,224.9

Warranty Information

Limited Warranty. Unless otherwise stated, your *product* (excluding the lamp) is covered by a one year parts and labor limited warranty. The lamp carries a 30-day warranty. It is the owner's responsibility to furnish receipts or invoices for verification of purchase, date, and dealer or distributor. If purchase date cannot be provided, date of manufacture will be used to determine warranty period.

Fog machine warning. Like all high quality video projection units, the DL.1 fixture must be kept protected from excessive amounts of glycol fog, mineral oil, and smoke. DL.1 incorporates two-stage air filtering to reduce these risks to a minimum; however, the user must follow these guidelines to ensure continued operation of the fixture:

- Air filters (both fixture and projector) should be checked and cleaned on a regular basis. When used in a closed or fixed environment where fog or haze is used, we recommend at least a weekly check.

- Do not situate DL.1 in areas of high fog density such as directly in front of a fog machine or mineral oil hazer.
- Minimize the exposure of DL.1 to both glycol fog and mineral oil.

DL.1 is a highly complex and sensitive electro-optical device and care and thought in how it is used, rigged, and positioned will maximize the product's life and your investment.

Failure to follow these guidelines and carry out regular maintenance will void the warranty.

Returning an Item Under Warranty for Repair. It is necessary to obtain a Return Material Authorization (RMA) number from your dealer or point of purchase BEFORE any units are returned for repair. The manufacturer will make the final determination as to whether or not the unit is covered by warranty.

Any Product unit or parts returned to High End Systems must be packaged in a suitable manner to ensure the protection of such Product unit or parts, and such package shall be clearly and prominently marked to indicate that the package contains returned Product units or parts and with an RMA number. Accompany all returned Product units or parts with a written explanation of the alleged problem or malfunction. Ship returned Product units or parts to: 2105 Gracy Farms Lane, Austin, TX 78758 USA.

Note: Freight Damage Claims are invalid for fixtures shipped in non-factory boxes and packing materials.

Freight. All shipping will be paid by the purchaser. Items under warranty shall have return shipping paid by the manufacturer only in the Continental United States. Under no circumstances will freight collect shipments be accepted. Prepaid shipping does not include rush expediting such as air freight. Air freight can be sent customer collect in the Continental United States.

REPAIR OR REPLACEMENT AS PROVIDED FOR UNDER THIS WARRANTY IS THE EXCLUSIVE REMEDY OF THE CONSUMER. HIGH END SYSTEMS, INC. MAKES NO WARRANTIES, EXPRESS OR IMPLIED, WITH RESPECT TO ANY PRODUCT, AND HIGH END SPECIFICALLY DISCLAIMS ANY WARRANTY OF MERCHANTABILITY OR FITNESS FOR A PARTICULAR PURPOSE. HIGH END SHALL NOT BE LIABLE FOR ANY INDIRECT, INCIDENTAL OR CONSEQUENTIAL DAMAGE, INCLUDING LOST PROFITS, SUSTAINED OR INCURRED IN CONNECTION WITH ANY PRODUCT OR CAUSED BY PRODUCT DEFECTS OR THE PARTIAL OR TOTAL FAILURE OF ANY PRODUCT REGARDLESS OF THE FORM OF ACTION, WHETHER IN CONTRACT, TORT (INCLUDING NEGLIGENCE), STRICT LIABILITY OR OTHERWISE, AND WHETHER OR NOT SUCH DAMAGE WAS FORESEEN OR UNFORESEEN.

Warranty is void if the product is misused, damaged, modified in any way, or for unauthorized repairs or parts. This warranty gives you specific legal rights, and you may also have other rights which vary from state to state.

What You Should Know About Copyright

Written By Suzy Vaughan Associates for High End Systems

I want to use a film clip from "When Harry Met Sally" in a promotional piece advertising my services. What do I have to do to be able to do that? First of all, you need to obtain permission to use the clip from its owners. The clip is considered intellectual property, just as though it were your car or some software code developed by and belonging to Microsoft. This is because the U.S. Copyright Act gave creators of literary works (which include books, films, television programs, art works, still photos and musical compositions and recordings) the right to sell or license these works and to make money from them for the period of the copyright.

But what about public domain material? I heard that lots of material is in the public domain and can be used for free. Once the copyright runs out, the creative work falls into the public domain and can be used freely by anyone without payment or licensing. If the work is not public domain, it is considered literary property. The Copyright Act provides substantial penalties for copyright infringement ranging from \$10,000 for accidental infringement to \$250,000 for willful infringement. However, contrary to popular belief, there really is not that much material in the public domain so this approach will limit you creatively.

What if I want to use a clip in a public performance? It's not being filmed or taped. Surely I don't need permission for that? Public gatherings require clearance whenever copyrighted data is projected to audiences, or for any use other than just personal viewing. Concerts, tradeshow, industrial shows, parties and raves are all examples of public performance and permission must be obtained.

Suppose I want to use a still photo or a magazine cover or a television clip? Do I have to obtain permission for them too? Yes, they are also copyrighted works, whose owners must grant a license for their usage.

Do I need any other permissions to use this material? In many cases you do. You may need to obtain permission to use the appearance of actors who appear in the clip as well as pay the writers and directors of the film that your clip comes from.

What about music? I hear you can use 8 bars for free. 8 bars for free is a fallacy that has been passed around as a fact for a long period of time. However, it isn't true. Both musical compositions and records require licensing and payment.

What about High End Systems material included with the Catalyst? Do I have to clear that? No. High End Systems has worked to provide clearance for the content that is provided with the Catalyst system. Any materials you received directly from HES with the purchase of a new Catalyst system have already been properly licensed for your use in shows and presentations. That does not, however, license you to sell this content separately from the Catalyst system. Also, please be sure that any new content you obtain from outside sources is properly cleared for public presentation.

This sounds really difficult and I don't know how to do it? What do I do to properly license copyrighted material?

You need to consult with a Content Clearing House or with a properly licensed Intellectual Property Attorney. Content clearinghouses are typically less expensive to work with and have well established industry relations that can result in cost savings. High End Systems uses and highly recommends Suzy Vaughan Associates. Suzy Vaughan Associates has 20 years of experience in clearing clips, talent, and music for use in any number of venues. Their clients include Barbara Streisand, Michael Jackson, and The Emmys among other shows.

You can obtain more information about Suzy Vaughan Associates' services by calling 818-988-5599 or emailing info@suzyvaughan.com. Their website is www.suzyvaughan.com. Suzy Vaughan is also an attorney specializing in intellectual property issues.

How much does it typically cost to license copyrighted material?

The answer depends entirely on what material you want to use and how you plan to use it. Prices can range from hundreds of dollars for photography content to thousands of dollars for a highly desirable film/video clip. Since price is content-sensitive, the best thing to do is to contact a clearinghouse like Suzy Vaughan Associates and let them find out for you.

Table of Contents

Contacting High End Systems®	-ii
Product Modification Warning	-iv
FCC Information	-iv
Important Safety Information	-v
Symbols	-v
Patents	-vi
Warranty Information.....	-vi
What You Should Know About Copyright	-viii
Table of Contents	-ix
List of Figures.....	-xiii

Chapter 1: Features and Specifications

Features	1-1
Operation.....	1-1
Optional Camera System.....	1-2
Optional Accessories	1-2
Specifications	1-3
Physical Specifications	1-3
Electrical Specifications	1-4
Projector Specifications.....	1-4
Environmental Specifications	1-4
Cable and Connector Specifications.....	1-5
Video Connectors:.....	1-5
DMX and RS-485 Projector Link.....	1-5

Chapter 2: Setup and Configuration

Unpacking the Fixture.....	2-1
Replacing the Power Cord Cap	2-1
Installing a Line Cord Cap - U.K. Only.....	2-2
Vatic Fitter Heads Information - Danmark	2-2
Connecting Video.....	2-2
Mounting the Fixture.....	2-4
Recommended Mounting Orientation	2-4
Fog Machine Warning	2-4
Mounting the Fixture Upright.....	2-5
Truss Mounting.....	2-5
Verifying the Truss Support.....	2-5
Clamps	2-5
Mounting Procedure	2-6
Linking the Fixtures.....	2-7
Data Cabling and Connectors	2-7

DMX Data Cables	2-7
Cable Connectors.....	2-7
Setting up the Link	2-8
Installing a Terminator.....	2-9
Powering On the Fixture	2-9
Homing the Fixture.....	2-9
Viewing the Display Panel	2-10
Verifying and Uploading Fixture Software.....	2-10
Setting the DMX Start Channel.....	2-11
Shutting Down the Fixture.....	2-12
Locking Pan and Tilt Positions	2-12

Chapter 3: Fixture Operation

TalkBack™ Support for Remote Access.....	3-1
The Menu Display	3-2
Navigational Basics.....	3-2
Display in Menu Locked Mode	3-3
Fixture Software Version	3-3
System Configuration Type.....	3-3
DMX Start Channel	3-3
Error Message Display	3-3
Unlocking the Menu System.....	3-3
Exiting the Menu System	3-3
Menu Map.....	3-4
Menu Option Descriptions	3-6
DMX Address Menu	3-6
Setting a DMX Start Channel	3-6
Set Parameters Menu	3-6
Factory Default Settings.....	3-6
Pan/Tilt Swap	3-7
Pan Invert	3-7
Tilt Invert	3-7
Display Level	3-8
Data Loss Timeout	3-8
Projector Input Source	3-8
Projector Default?	3-9
Reset Projector Hours.....	3-9
Striking the Projector Lamp.....	3-10
Projector In By DMX?.....	3-10
Iris Version	3-10
Zoom Override Menu	3-11
Focus Override Menu	3-11
Projector Control	3-11

Camera Option	3-12
Align Pan Motors	3-13
New Air Filter.....	3-13
Fixture Mode Menu	3-14
Crossloading Fixture Software	3-14
Test Options Menu.....	3-15
Homing the Fixture.....	3-15
Copying the Boot Code.....	3-15
Self Test Menu	3-16
Information Menu	3-16
Unique Number.....	3-16
DMX Values Menu.....	3-17
Temperatures Menu.....	3-17
Fixture Hours	3-18
Fixture Hours Reset.....	3-18
Lamp Hours.....	3-18
Projector Status.....	3-18
Projector Hours Reset.....	3-18
Software Version.....	3-18
Module Versions Menu.....	3-18
Display Errors	3-19

Chapter 4: DMX Programming

DMX Programming Overview	4-1
8-bit vs. 16-bit DMX.....	4-1
Lighting Consoles	4-1
Fixture Libraries	4-1
DMX Output Displays	4-2
16-bit DMX.....	4-2
Parameter Descriptions.....	4-3
Standard Movement and Projection Controls	4-3
Pan and Tilt	4-3
Dimming Iris	4-3
Focus.....	4-3
Zoom.....	4-3
MSpeed (Motor Speed)	4-3
Control Function Options.....	4-4
Changing Projector Source Input	4-5
Camera System Control	4-6
Camera Zoom.....	4-6
Camera Focus.....	4-6
IR Illuminator	4-6
Camera Shutter	4-6

White Balance	4-6
Orientation	4-6
Camera Effects	4-6
DL.1 Protocol Tables	4-7
Standard DL.1 Protocol	4-7
Enhanced DL.1 Protocol.....	4-8

Chapter 5: General Maintenance and Troubleshooting

Maintaining the Filtering System	5-1
Replacing Parts	5-2
Replacing Filters	5-2
Recalibrating the Filter System:	5-3
Replacing the Lamp	5-3
Replacing the Fuse.....	5-5
Cleaning or Replacing the Front Window.....	5-6
Replacing a Driver Board	5-7
Replacing 2-Phase Board.....	5-8
Replacing 3-Phase or CPU Board	5-8
General Troubleshooting.....	5-9
LED States	5-9
General Troubleshooting Suggestions	5-12

Appendix A: Safety Information

Appendice A : Importantes Informations Sur La Sécurité.....	A-2
Anhang A: Wichtige Hinweise Für Ihre Sicherheit	A-3
Apéndice A: Información Importante De Seguridad.....	A-4
Appendice A: Importanti Informazioni Di Sicurezza.....	A-5
Vigtig Sikkerhedsinformation.....	A-5

Appendix B: MSpeed Conversion Table

List of Figures

Figure 1-1: DL.1 Fixture Dimensions	1-3
Figure 2-1: Video Connectors	2-2
Figure 2-2: RGBHV Connectors	2-3
Figure 2-3: Attaching the Mounting brackets	2-6
Figure 2-4: Truss Mounting	2-6
Figure 2-5: XLR 5-pin connector	2-8
Figure 2-6: Linking DL.1 Fixtures	2-8
Figure 2-7: Data cable terminator	2-9
Figure 2-8: The DL.1 menu system navigation buttons	2-11
Figure 2-9: Pan and Tilt Locks	2-12
Figure 3-1: DL.1 fixture front panel display	3-2
Figure 3-2: DL.1 key map	3-11
Figure 3-3: Reading the DMX Values Menu Display	3-17
Figure 5-1: Replacing the Projector Filter	5-2
Figure 5-2: Replacing the HEPA Filter	5-3
Figure 5-3: Replacing the Fuse	5-5
Figure 5-4: Cleaning or Replacing the Front Window	5-6
Figure 5-5: Driver Board Configurations	5-7
Figure 5-6: DL.1 Rear Gasket	5-8
Figure 5-7: Accessing CPU and 3-phase boards.	5-8
Figure 5-8: Addressing screw and LED locations.	5-11

Chapter 1:

Features and Specifications

1

The DL.1 (Digital Light 1) fixture merges video projection and automated lighting technologies with a DMX controllable video light engine housed in a moving yoke fixture. DL.1 itself doesn't generate images; it is a mechanical means of displaying video images onto a stage with automated control of zoom, focus, and other video-related parameters. DL.1 fixtures can be used in conjunction with the Catalyst Media Server and Catalyst Version 3.0 software, or alone to project images from DVDs, videos and other compatible media.

The optional **Camera System** provides a fully equipped digital camera and IR illuminator to project live video on its local unit or another DL.1 fixture through an ethernet link. Combining camera and light from the same source allow for a unique point of view. Camera features include optical and digital zoom, frame rate and invert effects. Combining the camera with IR illuminator allows focus and fading in blackout situations. The ability to point the camera at it's own projection and adjusting zoom creates unique realtime video feedback and "hall of mirrors" effects.

This manual gives you information about the setup, operation and maintenance of the DL.1 fixture. For additional information specific to the projector housed in the DL.1 including projector maintenance, onboard menu and troubleshooting, see the projector's user manual shipped with your fixture.

Features

Operation

- DMX512 compatible control (pan, tilt, dimming iris, zoom, focus, and others)
- High resolution stepper motors (180,000 steps per revolution) to provide smooth, 16-bit movement control
- 400° pan, 270° tilt
- Variable 100–200V, 50/60Hz or 200-240V, 50/60Hz power input
- On-board menu system with dot matrix display
- Accepts RGBHV, VGA, S-Video inputs
- TalkBack™ protocol—standard in High End Systems automated luminaires, provides bi-directional communication to electronic feedback on sensor function, lamp life, and other details needed for maintenance purposes.

Optional Camera System

- Captures digital video in light or dark settings and inputs directly into the graphic engine.
- Optical + digital zoom can increase image upto 216×
- Scalable infrared output
- Built-in real-time video effects including:
 - Options for 1–30 frame captures / sec
 - Vertical and Horizontal image invert
 - B and White, Color Negative and Freeze Frame

Optional Accessories

The following table lists accessories available for the Catalyst system from your High End dealer/distributor. For more information, contact your High End Systems dealer/distributor or see “Contacting High End Systems®” on page ii.

Part Description	Part Number
Replacement air filter	80260014
5 amp, slow-blow fuse	90403012
Pan belt	99360038
Tilt belt	99360039
Front window	80530074
Camera System module	60040003
Digital Media Server	56020001
Wholehog III lighting console	61020001
LCD Monitor	56070009
Galvanized safety cable	12040001
Cheeseborough clamp	55040014
Lightwave Research Upload Dongle	26040002
Male 5-pin DMX terminator	90404039
Heavy duty 5-pin XLR cable (10')	55050017
Heavy duty 5-pin XLR cable (25')	55050018
Heavy duty 5-pin XLR cable (50')	55050019
Heavy duty 5-pin XLR cable (100')	55050020
User Manual	60600228

Specifications

Physical Specifications

Figure 1-1 shows the DL.1 fixture as shipped:

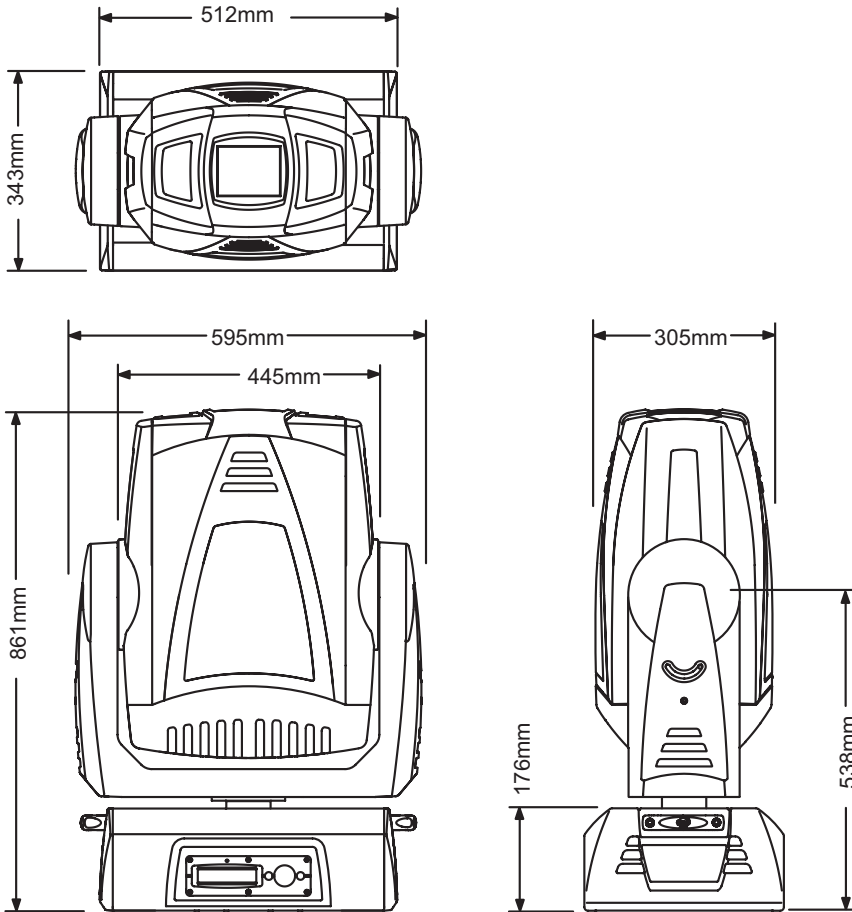

Figure 1-1 DL.1 Fixture Dimensions

Dimensions: 861mm × 595mm × 343mm
33.9in. × 23.4in. × 13.5 in.

Weight: 39 kg (85 lb)

Electrical Specifications



Warning: Class I equipment – This equipment must be earthed

Input ratings: 100—120V 6.8A 50/60Hz, 200—240V 3.4A 50/60Hz

Power factor: 0.94

Fuse: Power supply output fuse: 5A, 250V slow blow only.

Lamp: M275W NS4 POA-LMP47

Light Output: 4500 ANSI lumens

Lamp Life: 2000 hours

Projector Specifications

Aspect ratio: 4:3 native, 5:4 and 16:9 supported

Brightness uniformity: 95%

Contrast ratio: 800:1, full on/full off

Data compatibility: SXGA, XGA, SVGA, VGA, and Macintosh

Display technology: 1.3" TFT active matrix, 3 panels

Scanning frequency: H-sync, 15—100kHz; V-sync, 50—100Hz

Panel resolution: 1024 x 768 dots

Horizontal resolution: 800 TV lines (HDTV)

Projection lens: F=1.7—2.0 f=48.2mm~62.6mm

Zoom Lens Throw Ratio: 1.8 - 2.4:1

V-Sync range: 50—100Hz

Minimum focus distance to non-flammable surface: 1.4 m (4.6 ft)

Video compatibility: NTSC, NTSC4.43, PAL, PAL-M, PAL-N, SECAM, HDTV (1080i, 1035i, 720p, 480i, 480p, 575i, 575p)

Number of colors: 16.7 million

Environmental Specifications

Maximum ambient temperature (Ta): 35° C (95° F)

Cable and Connector Specifications

Video Connectors:

- RGBHV—BNC x 5
- VGA—DB15
- S-Video—mini-DIN

DMX and RS-485 Projector Link

Cables: Belden 9841 or equivalent (meets specifications for EIA RS-485 applications) with the following characteristics:

- Two 4-conductor twisted pairs plus a shield
- Maximum capacitance between conductors: 30 pF/ft
- Maximum capacitance between conductor and shield: 55 pF/ft
- Maximum resistance: 20 Ohm/100 ft
- Nominal impedance: 100–140 Ohm

Connectors: Two 5-pin male and female XLR connectors:

- Pin 1 Ground
- Pin 2 Data-
- Pin 3 Data+
- Pin 4 Secondary data-
- Pin 5 Secondary data+

Terminator: 5-pin male XLR connector with a 120 Ohm terminating resistor fitted between pins 2 and 3.

Chapter 2:

Setup and Configuration

2

Unpacking the Fixture

Your DL.1 fixture ships in a road case that is specifically designed to protect the product during transport. Unpack the DL.1 fixture and verify that it is undamaged. Inspect both the outside of the fixture and the projector for physical damage to components.

Your DL.1 fixture ships with the following:

- One road case
- One DL.1 fixture
- Two mounting brackets
- One projector manual
- One power cord

High End Systems® assumes no responsibility for products that are damaged during transport. Return a product for repair in its road case.

Before sending anything to the factory, call your High End Systems dealer/distributor for a Return Material Authorization (RMA) number. The factory cannot accept any goods shipped without an RMA number.

Replacing the Power Cord Cap

The SEOW cable shipped with the DL.1 fixture does not have an attached power cord cap. Different locations (even within the same country) may require a different power cord cap to connect the fixture to a power outlet.

Because of the variety of power cord caps used worldwide, High End Systems, Inc. cannot make specific recommendations for the power cord cap.

Contact a local authority for the type of power cord cap needed. When installing the power cord cap, note that the cores in the mains lead are colored in accordance with the following code:

- green and yellow = earth
- blue = neutral
- brown = live



Warning: Class 1 equipment - This equipment must be earthed.

Installing a Line Cord Cap - U.K. Only

In the United Kingdom, the colours of the cores in the mains lead of this equipment may not correspond with the colored markings identifying the terminals in the fixture's plug. Therefore, install a line cord cap in accordance with the following code:

- The core which is coloured green and yellow must be connected to the plug terminal which is marked with the letter “E,” or by the earth symbol \oplus , or coloured green, or green and yellow.
- The core which is coloured blue must be connected to the terminal which is marked with the letter “N” or coloured black.
- The core which is coloured brown must be connected to the terminal which is marked with the letter “L” or coloured red.



Warning: Class 1 equipment - This equipment must be earthed.

Vatic Fitter Heads Information - Danmark

Advarsel: Beskyttelse mod elektrisk chock.

Vigtigt!

Lederne med gul/groen isolation maa kun tilsluttes en klemme maerket

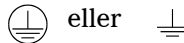

Connecting Video

The DL.1 fixture has three sets of video connectors on its rear panel, as shown in Figure 2-1.

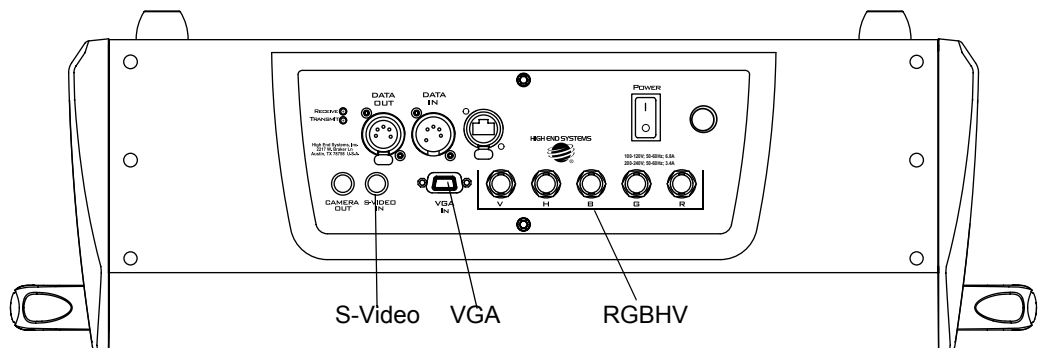

Figure 2-1 Video Connectors

Only one set of connectors at a time is active. You can set the active connectors using either the DL.1 menu system or the DMX protocol. To select an input, see “Menu Map” on page 3-4 first.



Caution: Do not physically connect both the RGBHV and VGA connectors. Doing so can cause damage to the fixture and void the warranty.

Figure 2-2 shows the RGBHV connectors in more detail:

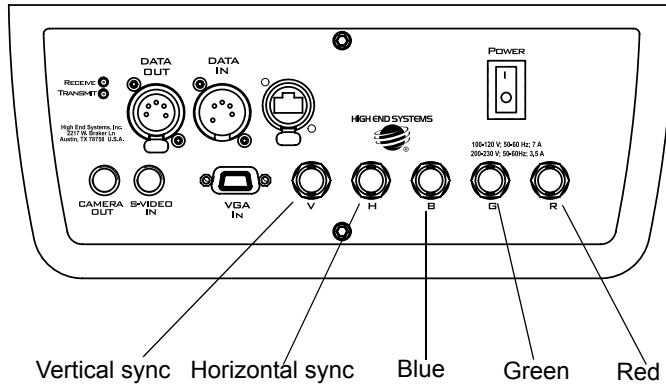

Figure 2-2 RGBHV Connectors

The projector provided with the DL.1 fixture makes a distinction between *inputs* and *sources*. Table 2-1 shows the relationship between DL.1 inputs and sources:

Table 2-1 DL.1 Inputs and Sources

Input	Source
Input 1	Not used by DL.1
Input 2	RGBHV or VGA
Input 3	S-Video

Mounting the Fixture

Recommended Mounting Orientation

High End Systems recommends mounting the DL.1 suspended vertically from a support system (such as a truss), permanently to the ceiling, or freestanding on its base.

Consider all the following Cautions and warnings before mounting the DL.1 fixture.



Caution: High End Systems does not recommend operation of the DL.2 fixture with the base perpendicular to the stage floor (fixture mounted sideways). Sideways mounting will result in significantly decreased lamp life.

Use a secondary safety cable when mounting this fixture.



Warnings: Equipment suitable for dry locations only. Do not expose this equipment to rain or moisture.



Maintain a minimum focus distance of 1.4 meters from combustible materials.



Do not mount on a flammable surface.

Fog Machine Warning

Like all high quality video projection units, the DL-1 fixture must be kept protected from excessive amounts of glycol fog, mineral oil, and smoke. DL-1 incorporates two-stage air filtering to reduce these risks to a minimum; however, the user must follow these guidelines to ensure continued operation of the fixture:

- Air filters (both fixture and projector) should be checked and cleaned on a regular basis. When used in a closed or fixed environment where fog or haze is used, we recommend at least a weekly check.
- Do not situate DL-1 in areas of high fog density such as directly in front of a fog machine or mineral oil hazer.
- Minimize the exposure of DL-1 to both glycol fog and mineral oil.

DL-1 is a highly complex and sensitive electro-optical device and care and thought in how it is used, rigged, and positioned will maximize the product's life and your investment.

Note: Failure to follow these guidelines and carry out regular maintenance will void the warranty.

Mounting the Fixture Upright



Caution: Do not mount the fixture upright without the four rubber feet.

To mount the fixture upright, make sure that all four rubber feet are installed on the fixture's base and place the fixture on a sturdy, stable surface that will support more than the 39 kg (85 lb) weight of the DL.1 fixture. If the surface is above floor height, use safety cables to secure the fixture to the surface.

You can optionally lock the DL.1's pan and tilt positions if desired, (see Figure 2-9 on page 2-12).

Note: The minimum focusable distance for the DL.1 fixture is 1.4 meters. Placing the DL.1 closer than 1.4 meters to any object won't allow it to focus properly.

Truss Mounting

Verifying the Truss Support

When mounting the fixture on a truss or another type of support, verify the truss or support will handle the combined weight of *all* the devices on the truss.

Verify that fixture clamps used are capable of supporting the weight of the fixture. Cheeseborough clamps for a two-inch truss are available from your High End Systems dealer/distributor (see "Optional Accessories" on page 1-2).

Note: Due to the wide variety of possible lighting designs, High End Systems cannot make specific mounting recommendations. Consider the following procedure as a suggested guideline only.

You will need:

- safety cables (1)
- cheeseborough clamps (2)
- locking washers (2)

Clamps

Always mount the DL.1 fixture with the cheeseborough clamps that shipped with your fixture and a safety cable attached (using the mounting bracket) to the fixture's base, shown in Figure 2-3. Do not use C- Clamps to mount the DL.1 fixture. You can remove the mounting clamps for floor applications.



Caution: Do not store loose clamps in the bottom of the road case, as they may cause damage to the unit head and output window.

Mounting Procedure

1. Disconnect power to the fixture. If it has been operating, allow the fixture to cool for five minutes before handling.
2. At least two people are required to mount the fixture with one person on each side supporting and attaching that side of the fixture. After the clamps are attached, one person can support the fixture while the other attaches safety cables.
3. Optionally lock the pan and tilt positions as discussed in “Pan and Tilt Locks” on page 2-12.
4. Attach two mounting brackets to the base of the fixture (as shown in Figure 2-3) using the provided quarter-turn screws.

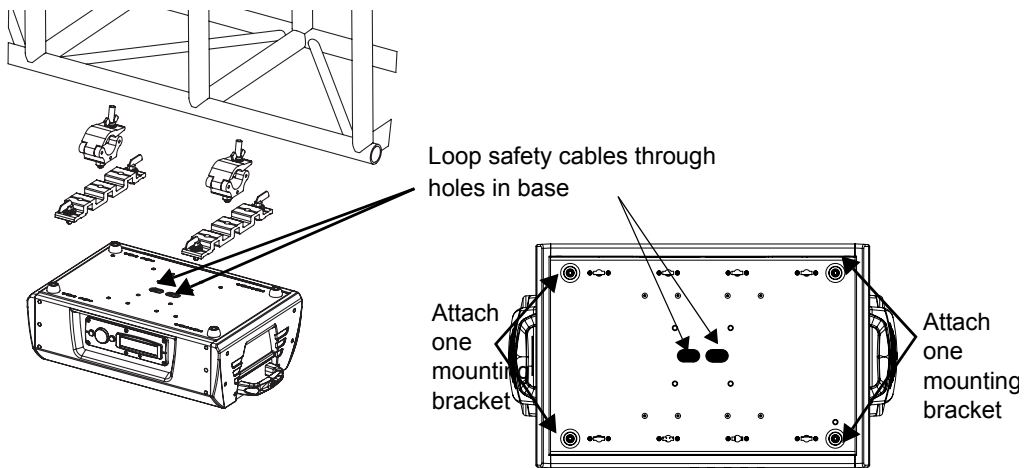

Figure 2-3 Attaching the Mounting brackets

5. Attach suitable cheeseborough clamps to the mounting bracket. Use locking washers when attaching the clamps to the fixture's base.
6. Tighten the clamps firmly to the fixture's base and to the support.
7. Loop one or more suitable safety cables around the support, around the fixture's base, and around the truss. Figure 2-4 shows an example:

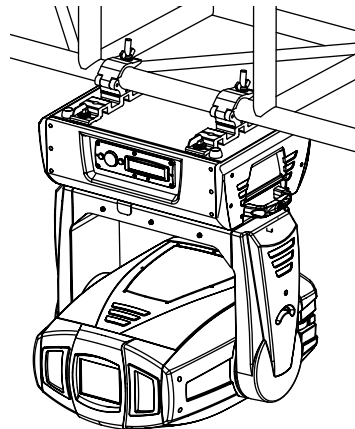

Figure 2-4 Truss Mounting

Linking the Fixtures

DL.1 fixtures can be linked to other fixtures on a standard DMX 512 link and then be controlled by a DMX controller.

The number of fixtures on a link will be determined by the combined number of channels required by all the fixtures. The DL.1 fixture requires 11 channels on a DMX 512 link.

Note: When connecting more than 32 fixtures to a link, use a DMX splitter. The 32 device limit complies with the EIA-485 standard. Connecting more than 32 devices per link without a DMX splitter will eventually deteriorate the digital signal.

Controllers, serial data distributors, data line optoisolators, and any fixtures using the RS-422 DMX standard of serial communications (including Dataflash® AF1000 xenon strobes, and Intellabeam® fixtures) block software uploads, crossloads, or TalkBack™ protocol on a link. Therefore, make sure to either put all of these devices after the DL.1 fixture on the link, or bypass these devices when performing software uploads or crossloads.

Data Cabling and Connectors

To link one or more fixtures to a controller and/or to each other, obtain data cabling. Cabling can be purchased from High End Systems or constructed.

High End Systems recommends data-grade cable. Data-grade cable is designed to carry a high-quality signal with less susceptibility to electromagnetic interference.

DMX Data Cables

Use Belden® 9842 or equivalent (meets specifications for EIA RS-485 applications) data cables with the following characteristics:

- Two twisted pairs (4-conductors) plus a shield
- Maximum capacitance between conductors: <15 pF/ft.
- Maximum capacitance between conductor and shield: 55 pF/ft.
- Maximum resistance: 20 Ω /1000 ft.
- Nominal impedance: 120 Ω

Cable Connectors

The DL.1 fixture accepts 5-pin XLR cable connectors. Cabling must have a male XLR connector on one end of the cable and a female XLR connector on the other end.

Pin one is the common (cable shield), pin two is the data complement (negative), pin three is the data true (positive). Pins four and five are not used, but they allow a secondary data link to pass through the fixture, (see Figure 2-5). Test each cable

with a voltage/ohm meter (VOM) to verify correct polarity and to make sure that the negative and positive pins are not grounded or shorted to the shield or to each other.



Caution: Do not connect anything to the ground lug on the XLR connectors. Do not connect or allow contact between the common (cable shield) and the fixture's chassis ground. Grounding the common could cause a ground loop and/or erratic behavior.

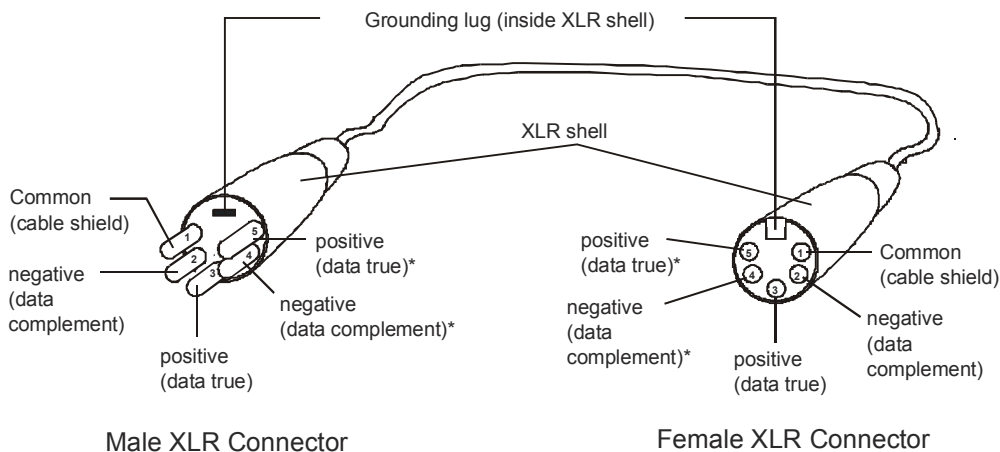

**This data line is not used by the fixture, but allows data to pass through the fixture.*

Figure 2-5 XLR 5-pin connector

Setting up the Link

To link one or more fixtures to a DMX controller as shown in Figure 2-6:

1. Connect a DMX Data cable's male XLR connector to a controller's DMX Data Out connector .

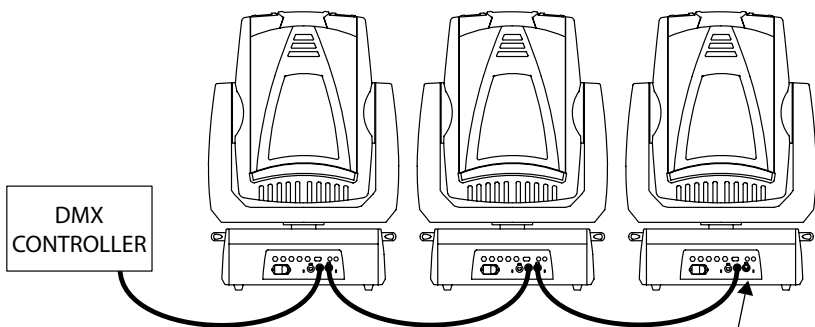

Figure 2-6 Linking DL.1 Fixtures

Terminate the last fixture on a DMX link.

2. Connect the Data cable's female XLR connector to the Data In connector of the first (or next) fixture on the DMX link.
3. Continue linking the remaining fixtures connecting a cable from the Data Out connector of each fixture to the Data In connector of the next fixture on the link.

4. Connect a male terminator to the Data Out connector of the last fixture in the link. For information on obtaining a terminator, see “Optional Accessories” on page 1-2.

Installing a Terminator

Install a 120 ohm, 1/4 watt (minimum) terminator in the fixture’s Data Out (female) cable connector in the *last* fixture on each DMX link. A terminator on the last fixture of the link prevents data reflection, which can corrupt the data communication on the link.

Purchase a terminator from a High End Systems dealer/distributor (see “Optional Accessories” on page 1-2), or follow the instructions below to construct a terminator.

To construct a terminator:

1. Disassemble a male 5-pin XLR connector.
2. Solder a 120 ohm resistor, minimum of 1/4 watt, between pins two and three.
3. Reassemble the XLR connector

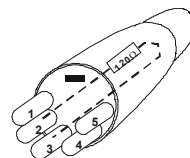

Figure 2-7 Data cable terminator

Powering On the Fixture



Caution: Do not power on the fixture until verifying that the line cord cap is suitable for the power source in your location.



Warning: This equipment for connection to a branch circuit having a maximum overload protection of 20 A.

To power on the DL.1 fixture, simply connect it to an appropriately-rated power source and turn the power switch located on the rear of the fixture to the ON (I) position. After being connected, controller commands can remotely power up or shutdown the fixture, (see “Control Function Options” on page 4-4 in the Standard Protocol table.) before performing procedures that require the fixture to be disconnected from power.

Homing the Fixture

When the DL.1 fixture is connected to an appropriately-rated power source, it automatically begins a homing procedure to verify that the major functions of the fixture and projector are oriented properly. The initial homing ends with the display in the Menu Locked mode.

Viewing the Display Panel

The DL.1 display panel gives access to the fixture's onboard menu system. "The DL.1 fixture's on-board menu system allows the user to:" on page 3-1 describes the menu system in detail.

Verifying and Uploading Fixture Software

Check the display in the Menu Locked mode to identify the Software version loaded on the fixture. Verify that the version displayed by the fixture is the latest available. The latest software for DL.1 fixtures is available in the support section of the High End Systems web site (www.highend.com). If a software upgrade is required, there are three ways to upload new software to DL.1 fixtures:

1. Attach a High End Systems Upload Dongle to the computer and upload the software to the DL.1 fixture.
A High End Systems Upload Dongle requires a 386-based (or faster) computer, MS DOS[®] version 3.3 (or later) or Windows 95/98/ME, and one MB of free disk space. To obtain an Upload Dongle (with installation and operation instructions), contact your High End Systems dealer/distributor (see "Contacting High End Systems[®]" on page ii).
2. Crossload software from one fixture that contains the new software to all other DL.1 fixtures on the link.
3. Upload the new software to all DL.1 fixtures on the link using a HandShake[™] handheld controller from High End Systems.

Note: Before uploading new software, disconnect any controllers, bypass any serial data distributors and/or data line optoisolators, and bypass or make sure that any fixtures using RS-422 communications (such as Dataflash[®] AF1000 xenon strobes, and Intellabeam[®] fixtures) are located after all the DL.1 fixtures on the link. These devices will block communication with any other DL.1 fixtures on the link

Setting the DMX Start Channel

Each standard configuration DL.1 fixture requires a block of 11 consecutive channels on a 512-Channel DMX link. A range of 20 Channels for Enhanced (Camera) Protocol is required for a DL.1 fixture equipped with the optional Camera System.

Up to forty-six 11-channel standard DL.1 fixtures (25 running Enhanced Protocol) can be assigned to a single 512-channel DMX link.

2

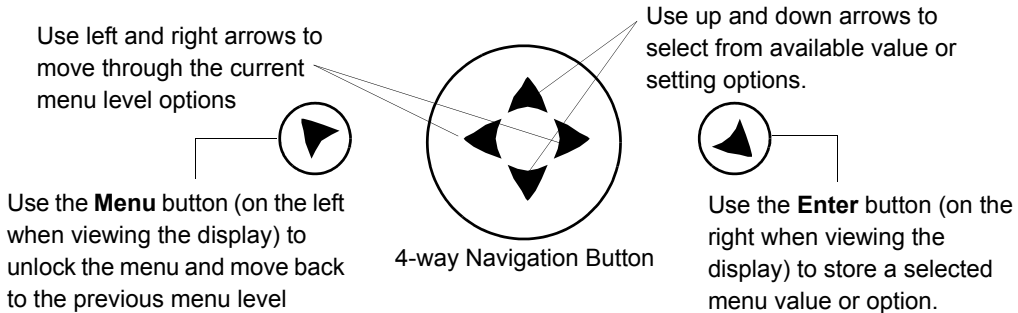

Figure 2-8 The DL.1 menu system navigation buttons

To set the start channel on an DL.1 fixture:

1. Access the fixture's menu system via the dot matrix display on the fixture's front panel. For a detailed description of the menu system, see Chapter 3.
2. Unlock the menu system by pressing and holding down the Menu button until the extended 2-line display appears. DMX ADDRESS MENU is the first option at the top menu level.
3. Press the Enter button to select. The display will show SET DMX START CHANNEL:###. The display will show the start channel currently assigned to the fixture.
4. Use the up and down arrow buttons on the Navigation button to select a new DMX start channel. The display will flash a new option ready for selection.

Note: The last valid start channel for a DL.1 fixture is 502 (512-11+1).

5. Press the Enter button to accept the new DMX Start channel. The display will stop flashing when a new option is entered. The new option will not be stored until the Enter button is pressed.

Shutting Down the Fixture

The DL.1 fixture automatically shuts down in the event of DMX data loss. A DMX controller can shut down the fixture remotely with the shutdown option in the control channel—see “Control Function Options” on page 4-4.

Locking Pan and Tilt Positions

Before shipping the DL.1 fixture, lock its pan and tilt in position so the fixture does not move during transit.

To lock the fixture:

1. Position the projector head as shown in Figure 2-9 to pack it in the road case.
2. Move the tilt lock peg to the upper left (locked) position.
3. Pull the pan lock latch out and move the fixture’s yoke to slide it around the pole located between the fixture body and the bottom of the yoke.
4. Release the pan lock, causing it to latch onto the pole.
5. Gently move the projector head and yoke to make sure both pan and tilt positions are locked in place.
6. Place the DL.1 fixture in its provided road case for shipping.

Note: You can optionally lock pan and tilt positions during operation in the event the projected image needs to remain in a fixed position.

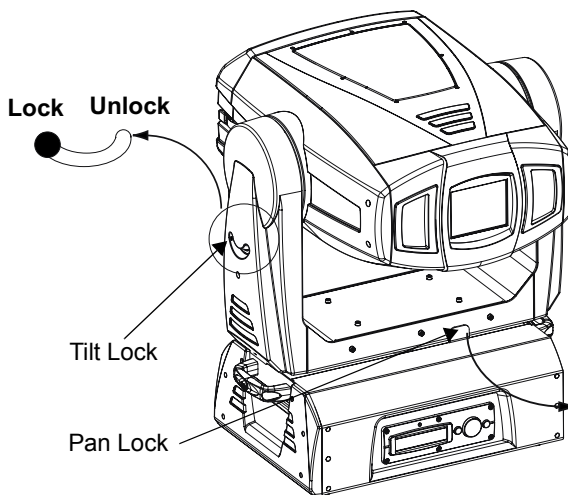

Figure 2-9 Pan and Tilt Locks

Chapter 3:

Fixture Operation

The DL.1 fixture operates on a DMX link to project output from any video source including from the Catalyst Media Server. This chapter outlines the DL.1 fixture's onboard menu system. For more information on operating the fixture with a controller, consult the controller documentation.

The DL.1 fixture's on-board menu system allows the user to:

- Set a start channel
- Enable and disable default parameter settings
- Crossload firmware
- Home the fixture
- Test movement and sensor functions
- View software version, temperature, lamp information, fixture information, DMX values, and errors.

TalkBack™ Support for Remote Access

All DL.1 fixtures support TalkBack™ technology. TalkBack™ technology allows remote access to the menu system built into High End Systems fixtures. A DMX controller supporting TalkBack can remotely access any option in the DL.1 onboard menu system.

TalkBack protocol uses the normal DMX-512 connection for bi-directional communication with the fixture so physical access to the fixture is no longer required to perform operations like changing a DMX address or configuring preset programs. TalkBack protocol utilizes the primary DMX link (pins 2-3) in a half-duplex communication mode. This means that it does not require pins 4-5 to be connected or used to receive TalkBack messages coming from the fixture.

TalkBack protocol uses a discovery process to find the unique number that is embedded inside each fixture, similar to a serial number. Once the fixtures have all been identified, the current fixture parameter settings and information can be accessed. Fixture access can happen at anytime, but the Talkback messages are only valid after the fixture starts homing.

The Menu Display

The front panel on the DL.1 fixture has a dot matrix display and six arrows on buttons that control navigation for the on-board menu system. The buttons are configured with the Menu button on the left and the Enter button on the right. The center button navigates through the current level of menu options [Left and Right] and values available for the current option [Up and Down].

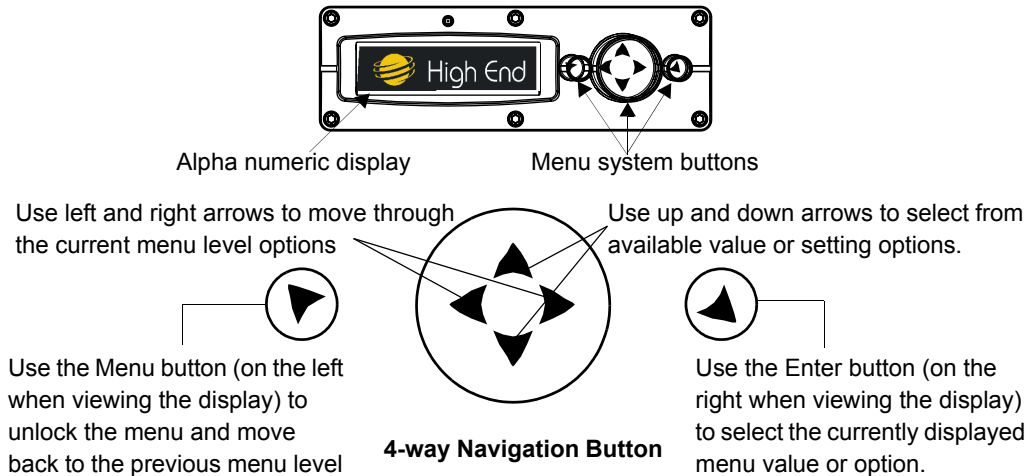

Figure 3-1 DL.1 fixture front panel display

Navigational Basics

1. Unlock the Menu system by pressing the Menu **▶** button for a few seconds until the display goes to the 2-line format.
2. Use the left and right arrows **◀▶** on the 4-way Navigation button to scroll through Menu options at the current level.
3. Stop at the desired menu and press the Enter **▲** button to select. The new option will not be stored unless the Enter button is pressed.
4. If there is another level of menu choices repeat Steps 2 and 3.
5. At the option or setting menu level, use the up and down arrows on the Navigation button **◆** to scroll to the desired option or setting. The option flashes until the Enter button is pressed. Pressing the Enter button stores the new value for that option. Pressing the Menu button returns to the previous menu level *without changing* the value of an option.
6. Continue pressing the Menu button to move back up levels and exit the menu system.

Display in Menu Locked Mode

The DL.1 fixture display panel gives access to the onboard menu system. When the menu system is in locked mode, the panel displays in large 8-character words designed to be viewed from a distance. Under normal circumstances, when the display is locked, it cycles between displaying the fixture's software version [V##.##], the High End Systems logo, the Catalyst logo, and the fixture's configuration type [STANDARD]. Any errors present are also displayed in an 8-character error description.

Fixture Software Version

The software version loaded on the system can vary even between units purchased at the same time. “Fixture Software Version” on page 3-3 describes the procedures to ensure that all Catalyst systems on the link are running the latest software.

System Configuration Type

The configuration type identifies the fixture as either STANDARD or CAMERA (equipped with a Camera System). A Standard configuration operates on 12 DMX channels. A Camera configuration requires 20 DMX channels for control.

DMX Start Channel

The DMX Start Channel is the first channel currently assigned to that fixture in its range of channels on a DMX link. For more information on DMX Start channels, see “Setting a DMX Start Channel” on page 3-6.

Error Message Display

Errors are displayed in short 8-character form when the menu system is locked. Unlocked, menu system's 2-line format displays more detailed information.

Unlocking the Menu System

To unlock the menu system, press and hold the Menu button until the display changes to the 2-line format. The menu system is protected against inadvertent menu changes by requiring the Menu button to be held for a few seconds before allowing entry to the menus. DMX Address Menu is the first option on the top menu level.

Exiting the Menu System

To exit the menu system, keep pressing the Menu button to back out of each menu level until the High End Systems logo appears. The word AUTOLOCK will appear briefly on the display to indicate the fixture's software is “locking” the display. The display switches back to the large 8-character format and, after a few seconds, begins the standard display for the locked mode as described above.

Menu Map

Use the following table to navigate the menu options on the DL.1 fixture.

Level 1	Level 2	Level 3	Option/Setting	Description/Notes
▼ enters /exits Menu System and moves up levels ◀ ▶ moves between items on same level. ▲ selects		▲ scrolls between values ▲ selects		
DMX ADDRESS MENU	SET DMX START CHANNEL:###	1-512		Selected value becomes the first DMX value in the range for that mirror head on a DMX 512 link.
SET PARAMETERS MENU	FACTORY DEFAULT SETTINGS:###	ON		Reverts to DL.1 default settings
		OFF		Indicates a factory default has changed
	PAN/TILT SWAP:	ENABLED		Swaps the Pan and Tilt Motion
		DISABLED		Restores default Pan and Tilt Motion
	PAN INVERT:	ENABLED		Inverts Pan motor direction
		DISABLED		Restores default Pan motor direction
	TILT INVERT:	ENABLED		Inverts Tilt motor direction
		DISABLED		Restores default Tilt motor direction
	DISPLAY LEVEL:	ON		Turns display on
		OFF		Display fully dimmed when menu is locked
	DATA LOSS TIMEOUT:	LONG		Shutter closes when fixture shuts down
		SHORT		Shutter closes one second after data loss
	PROJECTOR IN/SOURCE	RGBHV		Selects RGBHV or VGA
		SVIDEO		Selects S-Video
		NOT AVAILABLE		Displayed when PROJ IN BY DMX is enabled
	PROJCTR DEFAULT?	YES		Returns the projector to its factory default settings.
		NO		Leaves the projector's settings as they are.
	RESET PROJ HRS	YES		Press <Enter> for 5 seconds to reset projector hours
		NO		
	PROJ LAMP ON? XXX XXXXXXXXX	ON - TAKES 90 SEC		Select ON and Lamp will strike after a 90-second delay.
		OFF		
	PROJ IN BY DMX?	ENABLED		Set projector input using channel 11 of the DMX protocol.
		DISABLED		Set projector input using the menu system.
IRIS VERSION #### V1.0	PRE 1.0		Identifies fixture iris version	
	POST 1.0			
ZOOM OVERRIDE MENU VALUE:###	0-255		Manually sets DMX zoom value	
FOCUS OVERRIDE MENU VALUE ###	0-255		Manually sets DMX focus value	
PROJECTOR CONTROL ? TO EXIT -> MENU			Select to hand off control to Projector. Navigation buttons now control projector menu system. Use the MENU button used to exit this option.	
CAMERA OPTION	ENABLED		Camera System installed and using 20-channel DMX protocol.	
	DISABLED		Disables Camera System and reverts to 12-channel reduced DMX protocol.	
ALIGN PAN MOTORS XXXXX	YES		Aligns motors (30 minutes to complete)	
	NO/ABORT		Aborts align motors	
NEW AIR FILTER? XXX	YES		Selecting YES after new air filter installation calibrates the fixture.	
	NO			
FIXTURE MODE MENU	CROSSLOAD FIRMWARE	NO		Safe setting
		YES		Uploads fixture software to all other DL-1 fixtures on the link

Level 1	Level 2	Level 3	Option/Setting	Description/Notes	
▼ enters /exits Menu System and moves up levels ◀▶ moves between items on same level. ▲ selects		▲ scrolls between values ▲ selects			
TEST OPTIONS MENU	HOME FIXTURE:		ALL	Homes the projector head	
	COPY BOOT:		NO	Safe position: no action when selected	
			YES	Copies boot code to fixture	
	SELF TEST MENU:	CHASSIS TEST MENU:		PAN	Performs and displays all self test functions sequentially in the format: STEP:## DMX:###
				TILT	
				IRIS	
			FOCUS		
		ZOOM			
INFORMATION MENU	UNIQUE NUMBER #####			Displays fixture's unique number	
	DMX VALUES MENU	BY CHANNEL	1:XXX XXX XXX 4:XXX XXX XXX X:XXX XXX XXX X:XXX XXX XXX	Displays current values for Link Channels 001– 512 with 6 DMX values/screen. The first number in the line is the first channel # with a value displayed on that line.	
	TEMPERATURES MENU	CURRENT		INTAKE #####	Displays current temperature of selected sensor in centigrade
				LAMP #####	
				PANEL #####	
		MINIMUM		INTAKE MAX #####	Displays minimum temperature of selected sensor in centigrade
				LAMP MAX #####	
				PANEL MAX #####	
		MAXIMUM		INTAKE MIN ###	Displays maximum temperature of selected sensor in centigrade
				LAMP MIN #####	
				PANEL MIN #####	
		RESET		NO	Default "safe" setting
			YES	Press <Enter> for 5 seconds to reset all sensors to current temperature	
	FIXTURE HOURS ###:##				Displays fixture operation time in hours:minutes
	FIXTURE HOURS RESET:			NO	Default "safe" setting
				YES	Press Enter for 5 seconds to reset fixture hours to 0
	LAMP HOURS: ###:##				Displays lamp operation time in hours:minutes
	PROJECTOR STATUS XXXXXX			ON	Displays the Projector Status
				STANDBY	
	PROJ HOURS RESET 0				Displays the number of times Projector Lamp hours have been reset to 0
SOFTWARE VERSION VER XX.XX.XX				Display current Fixture software version Major.Minor.Build	
MODULE VERSIONS MENU			PAN 2*3 PHASE HW: XXX SW:XX TILT 2*3 PHASE HW: XX SW:XX RS232 INTERFACE HW: XX SW:XX FAN CONTROL HW: XX SW:XX ZOOM-FOCUS-IRIS HW: XX SW:XX DISPLAY	Displays the available Hardware and Software versions for each board .	
DISPLAY ERRORS MENU	XXXXXXXXXXXXXXXX XXXXXXXXXXXXXXXX			Scrolls through errors displayed in 2-line, 16-character format	

Menu Option Descriptions

DMX Address Menu

DMX address is the top level menu selection used to set the fixture's DMX start channel. Use this menu option, set a start channel or to change the *existing* DMX start channel to another DMX start channel.

Setting a DMX Start Channel

To set the DMX start channel:

1. Press the Menu button to unlock the menu system or to move back up the system to the top level menus. DMX ADDRESS MENU is the first menu item at the top level.
2. Press the Enter button to select. The display will show SET DMX START CHANNEL:###. The display shows the fixture's currently assigned start channel.
3. Use the up and down arrows on the Navigation button to select the same DMX start channel as the Media Server for the DL.1. The display will flash a new option ready for selection.

Note: The last valid start channel for an DL.1 is based on the channel range required by fixture's protocol mode. The last valid start channel for the DL.1 in standard mode (running without a Camera System) is 501 (512-12+1). The last valid start channel for the DL.1 in enhanced mode (with a Camera System) is 493 (512-20+1).

4. Press the Enter button to accept the new DMX Start channel.

Note: If the Enter button is not pressed, the old value will remain selected after exiting the menu.

Set Parameters Menu

The Set Parameters menu sets all factory options to their default settings or changes the factory options individually.

Factory Default Settings

If any of the factory default settings are changed, this menu reverts to the OFF option. The ON option restores all factory defaults.

To check and reset factory defaults:

1. Press the Menu button to unlock the menu system or to move back up the system to the top level menus.
2. Using the left and right arrows on the Navigation button, scroll through the top level to SET PARAMETERS MENU and press the Enter button to select.
3. Using the left and right arrows on the Navigation button, scroll to FACTORY DEFAULT SETTINGS. The current state (ON or OFF) will be displayed.

4. To reinstate the factory defaults if OFF is displayed, use the up and down arrows on the Navigation button to scroll to ON and press the Enter button to select.

Pan/Tilt Swap

This option swaps the pan motor and tilt motor operation.

To swap Pan and Tilt:

1. Press the Menu button to unlock the menu system or to move back up the system to the top level menus.
2. Using the left and right arrows on the Navigation button, scroll through the top level to SET PARAMETERS MENU and press the Enter button to select.
3. Using the left and right arrows on the Navigation button, scroll to PAN/TILT SWAP. The current state (ENABLED or DISABLED) will be displayed.
4. Use the up and down arrows on the Navigation button to scroll to ENABLED to swap pan and tilt or DISABLED to revert fixture to default setting and press the Enter button to select.

3

Pan Invert

This menu option inverts the direction of the pan motor to coordinate movements of fixtures in opposite directions.

To invert the fixture's Pan motion:

1. Press the Menu button to unlock the menu system or to move back up the system to the top level menus.
2. Using the left and right arrows on the Navigation button, scroll through the top level to SET PARAMETERS MENU and press the Enter button to select.
3. Using the left and right arrows on the Navigation button, scroll to PAN INVERT. The current state (ENABLED or DISABLED) will be displayed.
4. Use the up and down arrows on the Navigation button to scroll to ENABLED to invert Pan movement or DISABLED to revert fixture to default setting and press the Enter button to select.

Tilt Invert

This menu option inverts the direction of the tilt motor to coordinate movements between fixtures on a link facing each other vertically.

To invert the fixture's Tilt motion:

1. Press the Menu button to unlock the menu system or to move back up the system to the top level menus.
2. Using the left and right arrows on the Navigation button, scroll through the top level to SET PARAMETERS MENU and press the Enter button to select.
3. Using the left and right arrows on the Navigation button, scroll to TILT INVERT. The current state (ENABLED or DISABLED) will be displayed.

4. Use the up and down arrows on the Navigation button to scroll to **ENABLED** to invert Tilt movement or **DISABLED** to revert fixture to default setting and press the Enter button to select.

Display Level

Use this menu option to turn the display on or off.

To change display level:

1. Press the Menu button to unlock the menu system or to move back up the system to the top level menus.
2. Using the left and right arrows on the Navigation button, scroll through the top level to **SET PARAMETERS MENU** and press the Enter button to select.
3. Using the left and right arrows on the Navigation button, scroll to the **DISPLAY LEVEL**.
4. Using the up and down arrows on the Navigation button, choose **ON** to turn the display on or **OFF** to dim the display and press the Enter button to store the option.

Data Loss Timeout

Use this menu option to set the length of time required to close the shutter after DMX data loss.

To change data loss timeout:

1. Press the Menu button to unlock the menu system or to move back up the system to the top level menus.
2. Using the left and right arrows on the Navigation button, scroll through the top level to **SET PARAMETERS MENU** and press the Enter button to select.
3. Using the left and right arrows on the Navigation button, scroll to **DATA LOSS TIMEOUT**.
4. Using the up and down arrows on the Navigation button, choose **LONG** to set the fixture to close the shutter only when the fixture shuts down or **SHORT** to close the shutter about one second after DMX data loss.

Projector Input Source

Use this menu option to select either the RGBHV or S-Video inputs. The RGBHV setting also enables you to accept VGA input.

Note: If the PROJ IN BY DMX? is enabled, the fixture is receiving DMX input from a controller and the display for this menu will read NOT AVAILABLE. See "Projector In By DMX?" on page 3-10 to disable this menu option before setting Project Input Source .



Caution: Do not physically connect both the RGBHV and VGA connectors. Doing so can cause damage to the fixture and void the warranty.

To change projector input:

1. Press the Menu button to unlock the menu system or to move back up the system to the top level menus.
2. Using the left and right arrows on the Navigation button, scroll through the top level to SET PARAMETERS MENU and press the Enter button to select.
3. Using the left and right arrows on the Navigation button, scroll to PROJECTOR INPUT.
4. Using the up and down arrows on the Navigation button, choose RGBHV to enable the RGBHV or VGA inputs or choose SVIDEO to enable the S-Video input.

3

Projector Default?

Use this menu option to return the projector (as opposed to the DL.1 fixture) to its factory default settings. For more information about projector factory defaults, consult the projector manual shipped with the DL.1.

For example, if you previously set the projector input to an invalid state and you're not seeing output from the projector, resetting the projector to its defaults can cause the image to redisplay.

To set the projector to its factory defaults:

1. Press the Menu button to unlock the menu system or to move back up the system to the top level menus.
2. Using the left and right arrows on the Navigation button, scroll through the top level to SET PARAMETERS MENU and press the Enter button to select.
3. Using the left and right arrows on the Navigation button, scroll to PROJCTR DEFAULT?.
4. Using the up and down arrows on the Navigation button, choose YES to reset the projector or NO to leave the projector at its current settings.

Reset Projector Hours

Use this menu option to reset the Projector hours of use to zero:

1. Press the Menu button to unlock the menu system or to move back up the system to the top level menus.
2. Using the left and right arrows on the Navigation button, scroll through the top level to SET PARAMETERS MENU.
3. Using the left and right arrows, on the Navigation button, scroll to RESET PROJ HRS.
4. Using the up and down arrows on the Navigation button, select YES and hold for 5 seconds to reset the projector hours to zero.

Striking the Projector Lamp

The menu option PROJ LAMP ON? allows the operator to strike the lamp using the following steps:

1. Press the Menu button to unlock the menu system or to move back up the system to the top level menus.
2. Using the left and right arrows on the Navigation button, scroll through the top level to SET PARAMETERS MENU and press the Enter button to select.
3. Using the left and right arrows on the Navigation button, scroll to RESET LAMP ON?.
4. Using the up and down arrows on the Navigation button, scroll to YES. Press the Enter button. The lamp will strike after a 90 second delay.

Projector In By DMX?

By default, the menu identifies the input connection, (see “Projector Input Source” on page 3-8). Enabling this option allows you to control this option using channel 11 in the DMX protocol.

To put projector inputs under DMX control:

1. Press the Menu button to unlock the menu system or to move back up the system to the top level menus.
2. Using the left and right arrows on the Navigation button, scroll through the top level to SET PARAMETERS MENU and press the Enter button to select.
3. Using the left and right arrows on the Navigation button, scroll to PROJ IN BY DMX?.
4. Using the up and down arrows on the Navigation button, choose ENABLED to control projector input using the DMX protocol or DISABLED to control projector input using the DL.1 menu.

Iris Version

The menu system has built-in adaptations to accommodate changes to the Iris sensor location and interaction affect made in Version 1.0 of the fixture software.

To identify the fixture’s iris version:

1. Press the Menu button to unlock the menu system or to move back up the system to the top level menus.
2. Using the left and right arrows on the Navigation button, scroll through the top level to SET PARAMETERS MENU.
3. Using the left and right arrows on the Navigation button, scroll to IRIS VERSION. The display will show an iris version of PRE V1.0 or POST V1.0.

Zoom Override Menu

Use this menu option to override the zoom value sent the by the DMX console to the fixture. This feature is commonly used with PROJECTOR CTRL, which is discussed on page 3-11.

To select a DMX Zoom value:

1. Press the Menu button to unlock the menu system or to move back up the system to the top level menus.
2. Using the left and right arrows on the Navigation button, scroll through the top level to SET PARAMETERS MENU and press the Enter button to select.
3. Using the left and right arrows on the Navigation button, scroll to ZOOM OVERRIDE MENU.
4. Using the up and down arrows on the Navigation button, scroll to a DMX value between 0 and 255 and press the Enter button to select.

Focus Override Menu

Use this menu option to override the zoom value sent the by the DMX console to the fixture. This feature is commonly used with PROJECTOR CTRL, which is discussed on page 3-11.

To select a DMX Focus value:

1. Press the Menu button to unlock the menu system or to move back up the system to the top level menus.
2. Using the left and right arrows on the Navigation button, scroll through the top level to SET PARAMETERS MENU and press the Enter button to select.
3. Using the left and right arrows on the Navigation button, scroll to FOCUS OVERRIDE MENU.
4. Using the up and down arrows on the Navigation button, scroll to a DMX value between 0 and 255 and press the Enter button to select.

Projector Control

Use this menu option to toggle between the DL.1 menu system and the native projector menu system. The projector’s menu system is discussed in the projector manual provided with the DL.1 fixture.If you enable projector control, the DL.1’s function keys map to projector function buttons as shown in Figure 3-2:

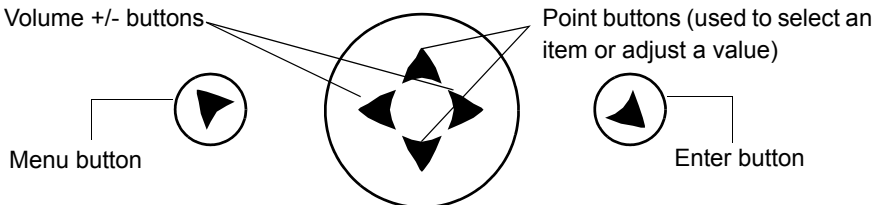

Figure 3-2 DL.1 key map

To enable projector control:

1. Press the Menu button to unlock the menu system or to move back up the system to the top level menus.
2. Using the left and right arrows on the Navigation button, scroll through the top level to SET PARAMETERS MENU and press the Enter button to select.
3. Using the left and right arrows on the Navigation button, scroll to PROJECTOR CTRL and press the Enter button to select .
4. Press the MENU button to return to the DL.1 menu system.

Limitations of Projector Control. The following projector options are not valid when you're controlling the projector with its menu system:

- Digital video connectors do not function
- RCA connectors do not function
- Input 1 (computer control) does not function
- The USB connector does not function
- Component video connectors do not function
- Audio in connectors do not function

The only valid inputs are: Input 2 (which selects the RGBHV or VGA connectors) and Input 3 (which selects the S-Video connector).



Caution: Do not physically connect both the RGBHV and VGA connectors. Doing so can cause damage to the fixture and void the warranty.

Camera Option

The DL.1 software automatically recognizes whether the fixture is equipped with the Camera System option and selects the appropriate protocol.

To disable the Camera System option installed in a fixture and revert to the 12-channel Reduced DMX Protocol:

1. Press the Menu button to unlock the menu system or to move back up the system to the top level menus.
2. Using the left and right arrows on the Navigation button, scroll through the top level to SET PARAMETERS MENU and press the Enter button to select.
3. Using the left and right arrows on the Navigation button, scroll to CAMERA OPTION. The current state will be displayed.
4. Use the up and down arrows on the Navigation button to scroll to DISABLED and press the Enter button to select.

Align Pan Motors

To realign the pan motors:

1. Press the Menu button to unlock the menu system or to move back up the system to the top level menus.
2. Using the left and right arrows on the Navigation button, scroll through the top level to SET PARAMETERS MENU and press the Enter button to select.
3. Using the left and right arrows on the Navigation button, scroll to ALIGN PAN MOTORS.
4. Use the up and down arrows on the Navigation button to scroll to YES and press the Enter button to select. The motor alignment sequence will begin.

Note: This operation takes 30 minutes to complete. Selecting NO/ABORT aborts the sequence.

New Air Filter

Installing a new air filter or installing a new CPU board requires fixture recalibration.

To calibrate the fixture after installing a new air filter:

1. Press the Menu button to unlock the menu system or to move back up the system to the top level menus.
2. Using the left and right arrows on the Navigation button, scroll through the top level to SET PARAMETERS MENU and press the Enter button to select.
3. Using the left and right arrows on the Navigation button, scroll to NEW AIR FILTER.
4. Use the up and down arrows on the Navigation button to scroll to YES and press the Enter button to select. The recalibration sequence will begin.

Fixture Mode Menu

The Mode menu crossloads software from one fixture to other fixtures on the link.

Note: Fixtures receiving the crossloaded data must not be in shutdown mode.

Crossloading Fixture Software

A fixture running a newer software version can load the new software to all other Catalyst systems on the link using the CROSSLOAD FIRMWARE menu option.

To CROSSLOAD FIRMWARE from one fixture to all DL.1 fixtures on the link:

1. Disconnect or bypass any controllers, serial data distributors, data line optoisolators, and any fixtures using RS-422 communications (such as Dataflash[®] AF1000 xenon strobes, and Intellabeam[®] fixtures). These devices will block communication between the crossloading fixture and any other fixtures on the link.
2. On the crossloading fixture *only*, unlock the menu system by pressing and holding down the Menu button until the extended 2-line display appears indicating the top menu level.
3. Using the left and right arrows on the Navigation button, scroll to the FIXTURE MODE MENU and press the Enter button to select.
4. Use the left and right arrows on the Navigation button to scroll to CROSSLOAD FIRMWARE.
5. Use the up and down arrows on the Navigation button to scroll to the YES option and press the Enter button to store. The fixture will upload its software to all other fixtures on the link.

When the crossload has finished successfully, CROSSLOADING COMPLETE will appear briefly in the display of the crossloading fixture, and all other fixtures will automatically home.

Note: If a new boot code was included with the latest software, the fixture displays a B00TDIFF error when it returns to the locked mode of the menu system. To correct the boot code, copy the new boot code to each fixture (see “Copying the Boot Code” on page 4-15).

Test Options Menu

The TEST OPTIONS MENU manually homes the fixture, performs fixture self tests, and stores new boot code information. Performing fixture self tests may help identify mechanical problems in the fixture.

Homing the Fixture

The fixture automatically homes all its functions whenever it is turned on. This menu option manually homes the entire fixture.

To remotely home the fixture using a DMX controller, see “Control Function Options” on page 4-4 in the DL.1 Standard Protocol table.

To manually home the fixture:

1. Press the Menu button to unlock the menu system or to move back up the system to the top level menus.
2. Use the left and right arrows on the Navigation button to scroll to the TEST OPTIONS MENU and press the Enter button to select.
3. Use the left and right arrows on the Navigation button to scroll to HOME FIXTURE.
4. Using the up and down arrows on the Navigation button, choose ALL to home the projector head or NO if you don't want to home the projector.

Copying the Boot Code

When new software is uploaded to a fixture, it may contain a new boot code which must be copied to each fixture. This is apparent if the fixture displays a BOOTDIFF error.



Caution: Do not remove power from the fixture while performing a boot copy.

To accept and store the new boot code:

1. Press the Menu button to unlock the menu system or to move back up the system to the top level menus.
2. Using the left and right arrows on the Navigation button, scroll to the TEST OPTIONS MENU and press the Enter button to select.
3. Using the left and right arrows on the Navigation button, scroll to the COPY BOOT option.
4. Use the up and down arrows on the Navigation button to scroll to the YES option and then press the Enter button to store the command. The fixture will store the new boot code, then automatically home.

Self Test Menu

This option displays the steps and DMX values generated as the fixture tests the motor operation of various functions. Self test can be run and viewed on all the fixture parameters sequentially, or individual parameters.

To access the SELF TEST MENU:

1. Press the Menu button to unlock the menu system or to move back up the system to the top level menus.
2. Use the left and right arrows on the Navigation button to scroll to the TEST OPTIONS MENU and press the Enter button to select. The menu displays CHASSIS TEST MENU.
3. Use the left and right Navigation buttons to scroll the function you wish to test.
4. Press the Enter button to select. The fixture begins running the self test on the selected function.

Information Menu

The Information menu displays current fixture information such as sensor status, total fixture hours, hardware and software versions, DMX errors, and DMX channel values. Fixture hours resets are also executed in the Information Menu.

Unique Number

Each DL1 fixture has a unique number similar to a serial number. TalkBack™ protocol uses this number to identify a fixture for remote communication over a DMX link. This option displays the fixture's Unique identification number.

To view the fixture's Unique number:

1. Press the Menu button to unlock the menu system or to move back up the system to the top level menus.
2. Use the left and right arrows on the Navigation button to scroll to the INFORMATION MENU and press the Enter button to select.
3. Use the left and right arrows on the Navigation button to scroll to the UNIQUE NUMBER option to view the fixture's 10-digit unique number.

DMX Values Menu

This menu displays the current values for the DMX link. When viewing DMX value settings by Channel, the DL.1 fixture displays current values for Channels 001–512 in two lines of three DMX values each per screen. Figure 3-3 shows an example of the first two lines displayed. The number at the beginning of each line indicates the first channel with a value displayed on that line.

The table below describes the first two lines displayed in the DMX Values Menu shown above it.

001	0	255	0
004	255	0	0

Scrolling down reveals additional channel values in the same format

Channel	DMX Value
001	0
002	255
003	0
004	255
005	0
006	0

Figure 3-3 Reading the DMX Values Menu Display

To View DMX Values:

1. Press the Menu button to unlock the menu system or to move back up the system to the top level menus.
2. Use the left and right arrows on the Navigation button to scroll to the INFORMATION MENU and press the Enter button to select.
3. Use the left and right arrows on the Navigation button to scroll to the DMX VALUES MENU option and press the Enter button to select. The display will read BY CHANNEL.
4. Press the Enter button to select.
5. Scroll through the DMX values listed to the desired Channel.

Temperatures Menu

This menu displays the fixture's internal temperature at the Intake and Lamp sensors in degrees centigrade.

To access the Temperatures Menu:

1. Press the Menu button to unlock the menu system or to move back up the system to the top level menus.
2. Use the left and right arrows on the Navigation button to scroll to the INFORMATION MENU and press the Enter button to select.
3. Use the left and right arrows on the Navigation button to scroll to the TEMPERATURE option and press the Enter button to select.
4. Use the left and right arrows on the Navigation button to scroll to CURRENT, MINIMUM, MAXIMUM, or RESET and press the Enter button to select.

OR, to reset internal temperatures to the Current temperature:

Use the left and right arrows on the Navigation button to select a sensor and press the Enter button to select, or (for the RESET option) select NO to not reset the sensors, or YES to reset all sensors to current temperatures.

Fixture Hours

Use this option to view the fixture operation time in hours and minutes.

Fixture Hours Reset

Use this option to reset the fixture operation time to zero.

To access the `FIXTURE HOURS RESET` option:

1. Press the Menu button to unlock the menu system or to move back up the system to the top level menus.
2. Use the left and right arrows on the Navigation button to scroll to the `INFORMATION MENU` and press the Enter button to select.
3. Use the left and right arrows on the Navigation button to scroll to the `FIXTURE HOURS RESET` option and press the Enter button to select.
4. Use the up and down arrows on the Navigation button to scroll to `YES`. Press and hold the Enter button down for 5 seconds to select.

Lamp Hours

Use this option to view the lamp operation time in hours and minutes.

Projector Status

Power to the internal projector can be turned ON or OFF with this option.

Projector Hours Reset

Selecting this option displays the number of times the projector lamp hours have been reset.

Software Version

This option display's the fixture's software version as: `V(Major).(Minor).(Build)`

Module Versions Menu

This option display's the hardware and software versions for the selected board .

The DL.1 fixture has the following driver boards:

- Pan
- Tilt
- RS232
- Fan
- Zoom-Focus-Iris
- Display

The menu displays `NOT AVAILABLE` if the version cannot be read from the selected board.

Display Errors

This menu option displays current errors in a descriptive 32-character text field.

To DISPLAY ERRORS:

1. Press the Menu button to unlock the menu system or to move back up the system to the top level menus.
2. Use the left and right arrows on the Navigation button to scroll to the INFORMATION MENU and press the Enter button to select.
3. Use the left and right arrows on the Navigation button to scroll to the DISPLAY ERRORS menu option and press the Enter button to select.
4. Use the up and down arrows on the Navigation button to view the list of current errors.

Chapter 4:

DMX Programming

DMX Programming Overview

A lighting console typically utilizes a protocol called DMX-512 to communicate with automated lighting fixtures and conventional dimmers. This protocol consists of 512 unique channels of control per output link (universe). Typically a lighting fixture or device will use a channel for each parameter's function. Each channel consists of 256 values ranging from 0 to 255. The lighting console is programmed to transmit a corresponding DMX value for the desired function of each parameter. All DMX values are stored within in the lighting console, and typically are referred to as cues, scenes, or presets.

4

8-bit vs. 16-bit DMX

Most parameters of an automated light use one channel of DMX providing 256 values of control (0-255). This is known as 8-bit DMX. Although several DL.1 parameters use 8-bit DMX, several require a more accurate range of values than can be provided with a single DMX channel.

By utilizing two DMX channels for a single parameter, 65535 values become available for controlling and adjusting parameter functions. This is known as 16-bit DMX. You can adjust 16-bit DMX values in both coarse and fine increments. The first channel of the pair provides coarse control changes of the DMX value in increments of 256. The second channel of the pair provides fine control and changes of the DMX value in increments of 1.

Lighting Consoles

Lighting consoles differ in many aspects and it is important to understand how your console operates with DL.1 fixtures.

Fixture Libraries

Many sophisticated lighting consoles utilize pre-made fixture libraries. A fixture library consists of profiles for various types of lighting fixtures and devices. Each profile corresponds to the fixture's DMX protocol and allows for ease of programming. Depending upon the manufacturer of your lighting console, some DL.1 parameters might have different labels for parameter names and functions than are listed within this manual. Consult your lighting console manual for further information.

DMX Output Displays

Although all lighting consoles output the same 512 channels of DMX per link, the on-screen labeling often differs. Parameter functions are displayed in either alpha-numeric descriptions (strobe 1), percentage (0-100%) or decimal (0-255 for 8-bit and 0-65535 for 16-bit). Consult your lighting console manual for further information.

16-bit DMX

Individual access of the two DMX channels used with 16-bit parameters varies by lighting console. Consult your lighting console manual for further information.

Parameter Descriptions

Note: All the DMX values identified in the following descriptions are in decimal units.

Standard Movement and Projection Controls

Pan and Tilt

Channels 1–4 control the Pan and Tilt parameters. The DL.1 fixture has a 400° pan range and a 270° tilt range. Two channels for Pan and two for Tilt provide 16-bit position adjustment to a fraction of a degree.

MSpeed values control the timing of pan and tilt motion for DL.1 fixtures, (see “MSpeed (Motor Speed)” on page 4-3). To control Pan and Tilt movement timing via DMX controller crossfading, set Pan/Tilt MSpeed off in the Control parameter (see “Control Function” on page 4-7 in the DMX Protocol Table.)

Note: Optical encoders for pan and tilt instantly correct the fixture’s position if the fixture is jarred from its programmed position. If a physical obstruction prevents the fixture from correcting its position, the fixture “times out” to prevent wear on the motors. If the fixture has timed out, remove the obstruction and home the fixture to return it to normal operation.

Dimming Iris

DL.1 fixtures have a mechanical iris that functions as a dimmer for the fixture output. This feature gives the operator the ability to fully shutter the output and eliminate the residual luminance from video black. Channel 5 controls the dimming iris adjustment from closed (DMX value = 0) to fully open (DMX value = 255).

Focus

Channel 6 controls the fixture’s mechanical focus from near (DMX value = 0) to far (DMX value = 255).

Zoom

Channel 7 controls the fixture’s mechanical zoom from narrow (DMX value = 0) to wide (DMX value = 255).

MSpeed (Motor Speed)

The MSpeed parameter is controlled with DMX Channel 12. MSpeed is the time required for a motor to complete movement when changing from one position to another. MSpeed provides a means for all motors to reach their target position at the same time, even though each motor may have different distances to travel. MSpeed movement is extremely smooth because the fixture controls movements independent of DMX refresh rates.

MSPeet times vary from 0.15 seconds to 252.7 seconds. However, when MSPeet is applied to a parameter, the delay value (length of time allowed for the entire scene) needs to be longer than the MSPeet value to allow the motors to complete their movement before the end of the scene. An MSPeet value that is longer than the delay value could produce an undesirable result; for example, an unintended “jump” to another position initiated before the first motion is complete. For a listing of exact MSPeet times, see “Appendix B: MSPeet Conversion Table”.

Note: Since Pan and Tilt are the only parameters controlled with MSPeet in DL.1 fixtures, setting the MSPeet Channel to Xfade (DMX value = 0) or the Control Channel to MSPeet Off (DMX value = 10-13) will have the same outcome.

Control Function Options

Channel 10 operates several Control functions. These functions remotely control various fixture operations and allow access to the internal-projector menu controls.

Fixture operations . All of the following Fixture operation control settings except for Turning MSPeet off require Channel 5 (Dimming Iris) be closed (DMX decimal value = 0). These control options allow the user to:

- Turn MSPeet off
- Turn the display on and off
- Adjust display brightness
- Home
 - All the fixture components
 - Pan and Tilt
 - Focus/Zoom/Dimming Iris
- Turn Lamp on and off
- Shutdown the fixture
- Reset the Camera

Internal Menu Access. The following Control options do not require Channel 5 be set to Closed (DMX value = 0). They allow the user to access the:

- Projector Menu
- Projector Up / Down / Left / Right
- Projector Select
- Projector Orientation

These values enable you to access the projector’s menu system under DMX control. For details about these features and about the projector’s menu system, you must consult the projector manual provided with the DL.1. For a list of limitations on these features, see “Limitations of Projector Control” on page 3-12.

To use the native projector menu system under DMX control:

1. Send DMX decimal value 180–184 (Menu button) on Channel 10 to access the projector’s main menu. Send a DMX value in the “safe” range (0–9).

This command is equivalent to releasing the key on the projector’s keypad.
Failure to release the key will result in unpredictable performance.

Optional. If the projector is mounted on the ceiling, flip the display by sending a value from 205–208 on Channel 10.

2. Use Channels 1 through 4 to adjust the pan and tilt to direct the projector to a suitable surface so you can view its on-screen display.
3. Adjust Zoom (Channel 7) and Focus (Channel 6) as needed to bring the projector’s on-screen display into focus.
4. Use the projector’s on-screen display as discussed in the projector manual provided with the DL.1 fixture.
5. To exit the projector’s menu system, repeat steps 2 and 3.

Projector Orientation. Projector Floor Orientation, Projector Ceiling Orientation, Projector Front Projection and Projector Rear Projection are active commands – i.e. they do not require the dimming iris value to be at zero to operate.

Once set, these commands maintain their value until reset even after shutdown and re-homing. For example, if the Control channel is set to DMX decimal value of 210 to switch the unit to Ceiling operation, then the unit will remain in Ceiling orientation until another command is sent to switch back to Floor. This allows the Control channel to revert to its safe value or some other value without losing the orientation or mirroring status.

Changing Projector Source Input

S-Video input can be utilized with either RGBHV or VGA but not both. You can select between RGBHV and VGA in the menu system, (see “Projector Input Source” on page 3-8). RGBHV is the factory default. You can also select the Projector Input via DMX using Channel 11.

Note: Before being able to use the DMX protocol to select projector source input, you must enable the PROJ IN BY DMX? menu option, see “Projector In By DMX?” on page 3-10.

Once the selection is made, allow about 10 seconds for the change to take effect .



Caution: Do not physically connect both the VGA and the RGBHV connectors at the same time. Doing so can damage the projector and void the warranty.

Camera System Control

Camera Zoom

The Camera Zoom parameter provide 16-bit control of the camera Zoom function. The Zoom includes 18× optical and 12× digital zoom (216× combined). Adjust Zoom from In (DMX value = 0) to Out (DMX value = 65535)

Camera Focus

The Camera Focus parameter provide 16-bit control of the camera Focus function. Auto focus is active at DMX values = 0–511. Set Manual focus from In (Far End) value = 512 to Out (Near End) value = 65535.

IR Illuminator

DL.1 fixtures with an integrated Camera System are equipped with an infrared illuminator that can output infrared (IR) light for operating in a night vision mode. The IR Illuminator parameter controls both the IR illuminator output and the camera's infrared sensing option. DMX values = 0 – 63 are the default with illuminator off and the camera set to sense the visible light spectrum. From DMX values = 64–127, the Illuminator remains off, but the camera's Auto IR function is ON detecting ambient infrared light in the environment. The rest of the range turns the Auto adjustment off and adjusts the amount of IR illuminator output from FULL (DMX value = 128) to OFF (DMX value = 255).

Camera Shutter

You can create slow-motion and choppy-frame effects using the camera shutter options. The Camera Shutter parameter provides six steps of frame rate control from 1 to 30 frames/second. DMX values = 0 – 63 set Full Auto Exposure and is the default option.

White Balance

The White Balance parameter adjusts for the variation in what is perceived as “White” in different light conditions. The Auto White Balance mode computes the white balance value output using color information from the entire screen. It outputs the proper value using the color temperature on a range of values from 3000 to 7500K and is the default setting. Other settings for this Parameter accommodate Indoor and Outdoor lighting conditions.

Orientation

You can Vertically Invert (Flip) or Horizontally Invert (Mirror) the image being viewed by the camera using the Orientation parameter. All four combinations of Vertical and Horizontal Invert are available.

Camera Effects

The Camera Effects parameter can convert an image to black and white (B&W), or can invert the color (Negative art). A snapshot can also be taken of the image (Freeze Frame) with or without one of these effects applied.

DL.1 Protocol Tables

DL.1 fixtures offer two protocol levels —Standard and Enhanced. Standard Protocol controls fixture movement and output features. Running Enhanced protocol provides an additional nine channels for controlling Digital Eye Technology and increases the fixture footprint on the DMX link from 11 to 20.

Standard DL.1 Protocol

Chan #	Function	Description	Value dec.	Value %	Default dec.		
1 2	Pan Position	Moves projector head from 0°–400°	0-65535	0-100	32768		
3 4	Tilt Position	Moves projector head from 0°–270°	0-65535	0-100	32768		
5	Dimming Iris	Adjusts the mechanical iris located in front of the projector output lens from closed to open	0-255	0-100	0		
6	Focus	Adjusts focus from near to far	0-255	0-100	128		
7	Zoom	Adjusts zoom from narrow to wide	0-255	0-100	128		
8	MSpeed	See Appendix B for conversion tables	0-255	0-100	0		
9	Macro	Reserved for future use	n/a	N/A	0		
10	Control Function	Safe	0-9	0-4	0		
		Pan and Tilt MSpeed off	10-13	5-7			
		Display Off	20-28	8-11			
		Display Dim	30-38	12-15			
		Display Bright	40-48	16-19			
		Home All	60-68	24-27			
		Lamp ON	80-88	32-35			
		Lamp OFF	90-98	36-39			
		Shutdown	120-130	47-51			
		Reserved	131-149	52-58			
		Camera Reset	150-155	59-61			
		Home Pan/Tilt	160-168	62-66			
		Home Focus/Zoom/Dimming Iris	170-178	67-70			
		Using the Projector's Menu System—see page 4-4					
		Projector Menu	<i>(These Control options require Channel 5 = 0)</i>	180-184		NA	
		Projector Up		185-188			
		Projector Down		189-192			
		Projector Left		193-196			
		Projector Right		197-200			
		Projector Select		201-204			
Projector Floor Orientation	205-208						
Projector Ceiling Orientation	209-212						
Projector Front Projection	213-216						
Projector Rear Projection	217-220						
Reserved	221-255	87-100					
11	Input Source Select <i>(See page 4-5)</i>	Safe	0-31	0-12	32-47		
		RGBHV (Default)	32-47	12-18			
		S-Video Input 3	48-63	19-25			
		Internal Source Input 1	64-79	25-31			
		Reserved for future use	80-255	31-100			



Enhanced DL.1 Protocol

Fixtures with Digital Eye Technology accessory require these additional nine channels.

Chan #	Function	Description	Value dec.	Value %	Default dec.
12 13	Camera Zoom (16 bit adjustment)	Auto Zoom position	0-65535	0-100	32768
14 15	Camera Focus (16 bit adjustment)	Auto Focus position	0-511	0-1	0
		Focus In (Far End) to Out (Near End)	512-65535	2-100	
16	Infrared Illuminator	Camera's IR sensing OFF, illuminator OFF	0-63	0-24	0
		Camera's IR Auto sensing ON, Illuminator OFF	64-127	25-49	
		Camera's IR Manual sensing ON, Illuminator scaled across the range from FULL to OFF	128-255	50-100	
17	Shutter	Auto Exposure=Full Auto	0-63	0-25	0
		Auto Exposure=Shutter Priority, Shutter Speed = 30	64-95	26-38	
		Auto Exposure =Shutter Priority, Shutter Speed = 15	96-126	39-49	
		Auto Exposure=Shutter Priority, Shutter Speed = 8	127-157	50-62	
		Auto Exposure=Shutter Priority, Shutter Speed = 4	158-188	63-74	
		Auto Exposure=Shutter Priority, Shutter Speed = 2	189-219	75-86	
18	White Balance Mode	Auto Focus	0-63	0-25	0
		Indoor	64-95	26-38	
		Outdoor	96-127	39-50	
		Reserved - no change from previous state	128-255	51-100	
19	Orientation	Flip OFF, Mirror OFF	0-63	0-25	0
		Flip OFF, Mirror ON	64-127	26-50	
		Flip ON, Mirror OFF	128-191	51-75	
		Flip ON, Mirror ON	192-255	76-100	
20	Camera Effects	Freeze Frame OFF, Negative Art OFF, B&W OFF	0-63	0-25	0
		Freeze Frame ON, Negative Art OFF, B&W OFF	64-127	26-49	
		Freeze Frame OFF, Negative Art ON, B&W OFF	128-159	50-62	
		Freeze Frame ON, Negative Art ON, B&W OFF	160-191	63-75	
		Freeze Frame OFF, Negative Art OFF, B&W ON	192-223	76-88	
		Freeze Frame ON, Negative Art OFF, B&W ON	224-255	89-100	

Chapter 5:

General Maintenance and Troubleshooting

This chapter includes information on replacing parts, and cleaning the fixture. Please note the warnings under each heading before servicing the fixture.

The following toolset should be all you need for the maintenance procedures in this chapter:

- M3 allen wrench
- M4 allen wrench
- #2 Phillips screwdriver
- Gloves
- Protective eyewear
- Mild glass cleaner (containing no ammonia) and a soft, lint-free cotton cloth



Warning: This fixture must be serviced by qualified personnel. The information listed in this chapter is intended to assist qualified personnel *only*.

Maintaining the Filtering System

Like all high quality video projection units, the DL-1 fixture must be kept protected from excessive amounts of glycol fog, mineral oil, and smoke. DL-1 fixture is equipped with a two-stage air filtering to reduce these risks to a minimum:

- The prefilter is designed to keep out large dust and debris such as from pyrotechnics and confetti.
- The HEPA filter is designed to aid in filtering small particles of dust, cigarette smoke, fog and haze. The HEPA filter will require changing more often if the DL-1 is exposed to theatrical fog or smoke. Depending on the levels of exposure filter life can vary dramatically.

The Projector housed inside the DL.1 fixture contains an additional filter.

Fixture filters should be checked and cleaned on a regular basis. When used in a closed or fixed environment where fog or haze is used, a weekly check is recommended.



Caution: Minimize the exposure of DL-1 fixtures to both glycol fog and mineral oil. Do not situate DL-1 in areas of high fog density such as directly in front of a fog machine or mineral oil hazer.

Replacing Parts



Warnings: Disconnect power before servicing.



Replace fuses with the specified type and rating only.

Equipment surfaces may reach temperatures up to 130° C (266° F). Allow the fixture to cool before handling.

Replacing Filters

The fixture filters should be checked whenever the display flashes SERVICE FILTER.

Access the fixture filter:

1. Lock the fixture head in place using the 90° pan lock and the 0° tilt lock settings as shown in Figure 2-9 on page 2-12.
2. Unlatch and remove the rear bezel assembly.
3. Loosen the two quarter-turn screws on the top cover and remove the cover.
4. Slide the top cover back to free it from the front bezel.

Inspect the filters:

5. Lift the prefilter away from the filter bracket
6. Remove the two philips pan screws securing the filter bracket and lift the filter unit off the fixture.
7. Remove the bracket and lift the HEPA filter out of the filter housing. Inspect both the prefilter and the HEPA filter.

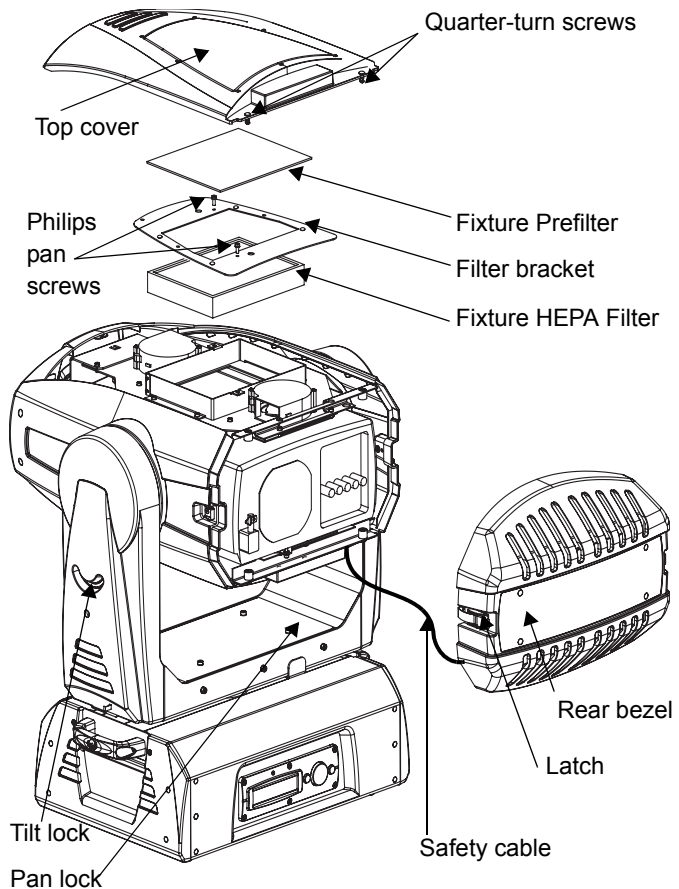

Figure 5-1 Replacing the Projector Filter

8. A dirty prefilter can cause an early Service Filter warning. If the prefilter looks dirty, clean it with water. Thoroughly dry the prefilter before proceeding.
9. If the HEPA filter is discolored with particulates, replace it *only* with the part listed in “Optional Accessories” on page 1-2.

Reassemble the fixture:

10. Reinstall the HEPA Filter with the rubber gasket down as shown in Figure 5-2.
11. Reattach the filter bracket with the two philips pan screws.
12. Replace the prefilter over the bracket on velcro tabs.
13. Replace the top cover, fastening it with the two quarter-turn screws.
14. Carefully replace the rear bezel, making sure to place (but *do not force*) the gasket (shown in Figure 5-6 on page 5-8) against the lamp cover located on the projector back of the projector.
15. Relatch the rear bezel assembly (see Figure 5-1).

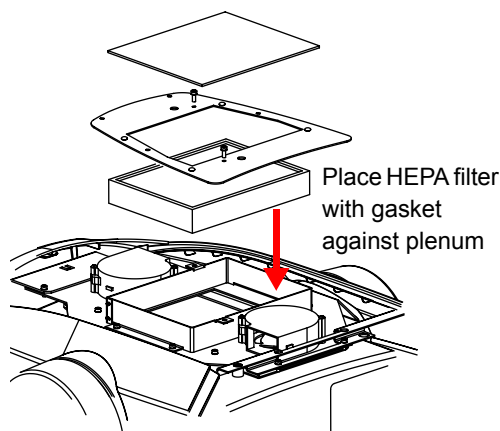

Figure 5-2 Replacing the HEPA filter

5

Recalibrating the Filter System:

Before recalibrating, ensure that:

- **The fixture is attached to a DMX controller**
- **The fixture is cooled to room temperature**

To calibrate the fixture after installing a new air filter or new CPU board:

1. After the fixture is cooled, apply power and then, while the fixture is homing perform the following menu configuration procedure.
2. Press the Menu button to unlock the menu system or to move back up the system to the top level menus.
3. Using the left and right arrows on the Navigation button, scroll through the top level to SET PARAMETERS MENU and press the Enter button to select.
4. Using the left and right arrows on the Navigation button, scroll to NEW AIR FILTER.
5. Use the up and down arrows on the Navigation button to scroll to YES and press the Enter button to select.
6. After a 20 second pause, you will hear the fans ramp up to high speed as the recalibration sequence begins and then ramp down.

Note: If you turn off the power before you hear the fans engage, the filters will not be calibrated.

Replacing the Lamp



Warning: Equipment surfaces may reach temperatures up to 130° C (266° F). Do not attempt to hot-restrike the lamp. Allow the fixture to cool before handling or restriking the lamp.

To replace the lamp:

1. Lock the fixture head in place using the 90° pan lock and the 0° tilt lock settings as discussed in Figure 2-9 on page 2-12.
2. Unlatch and remove the rear bezel assembly.
3. Consult the projector manual (shipped with the DL.1 fixture) for lamp replacement instructions.
4. Carefully replace the rear bezel, making sure to place (but *do not force*) the gasket (shown in Figure 5-6 on page 5-8) over the lamp cover located on the back of the projector.
5. Relatch the rear bezel assembly.

Replacing the Fuse



Warnings: Disconnect power before servicing.



Replace fuses with the specified type and rating only.

**Equipment surfaces may reach temperatures up to 130° C (266° F).
Allow the fixture to cool before handling.**

The DL.1 has one user-serviceable fuse which controls mains voltage to the fixture.

To replace a fuse:

1. Disconnect power to the fixture. If the fixture has been operating, allow the fixture to cool before handling.
2. Remove the six M4 socket cap screws from the motor power supply side of the fixture, as shown in Figure 2:

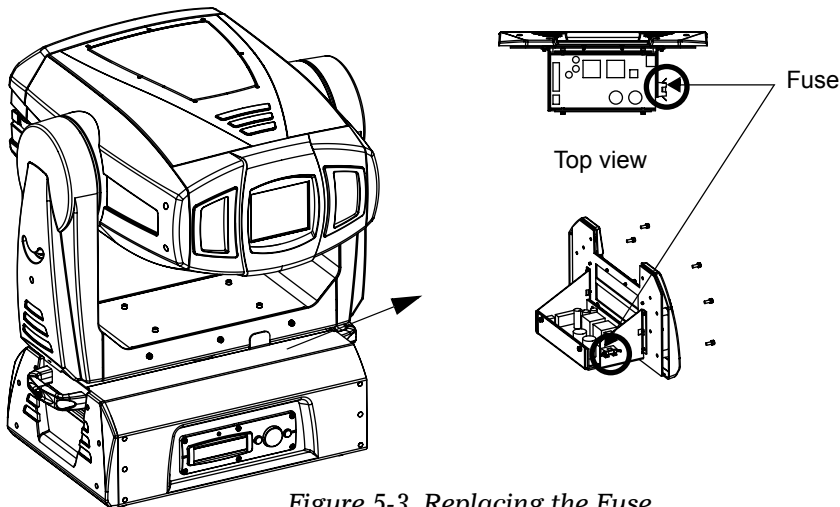

Figure 5-3 Replacing the Fuse

3. Slide the side assembly out.
4. Locate the fuse holder (circled in Figure 2).
5. Remove the fuse from the fuse holder.
6. Replace the fuse with a 5A, slow-blow fuse *only*.
7. Replace the side assembly.



Caution: Make sure you align the assembly properly when inserting; damage to the fixture can result from improper alignment.

8. Replace the six M4 socket caps that secure the side assembly to the fixture.

Cleaning or Replacing the Front Window



Warnings: Disconnect power before servicing.



**Equipment surfaces may reach temperatures up to 130° C (266° F).
Allow the fixture to cool before handling.**

To clean the internal glass components:

1. Disconnect power to the fixture. If the fixture has been operating, allow the fixture to cool for at least 5 minutes before handling.
2. Remove the four M5 socket cap screws (two on each side of the front bezel), as shown in Figure 5-4:

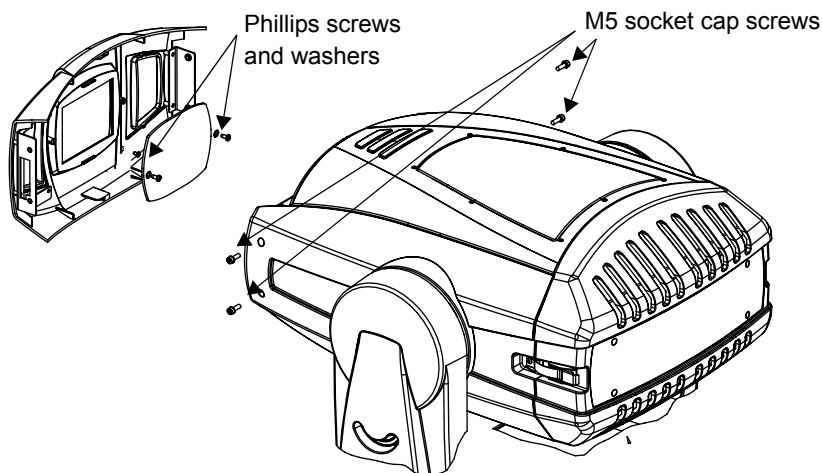

Figure 5-4 Cleaning or Replacing the Front Window

3. Slide the bezel from the front of the fixture.
4. Inside the bezel, locate the two Phillips head screws and washers securing the front window in place.
5. Remove the screws, making sure not to misplace the washers.
6. *To clean the front window:* Clean the front window using a mild glass cleaner (containing no ammonia) and a soft, lint-free cotton cloth.
7. *To replace the front window:* Replace the window with the part specified in “Optional Accessories” on page 1-2.
8. Carefully replace the Phillips screws and washers, making sure not to break the glass.



Caution: Use plastic washers only when replacing the front glass. Using metal washers can damage the glass.

9. Replace the front bezel.

Replacing a Driver Board



Warnings: Disconnect power before servicing.



**Equipment surfaces may reach temperatures up to 130° C (266° F).
Allow the fixture to cool before handling.**

The DL.1 fixture is designed with two basic types of motor driver boards:

- One 2-phase board drives the motors for the focus/zoom/dimming iris functions.
- Interchangeable 3-phase pan and tilt driver boards. Addressing screw placement determines whether the board has pan or tilt driver functionality.

In addition, the DL.1 fixture has a CPU board located inside the fixture chassis with the 3-phase board. Figure 5-5 shows the location of the driver boards and landmarks you can use to locate functional areas (and LEDs) on the boards themselves:

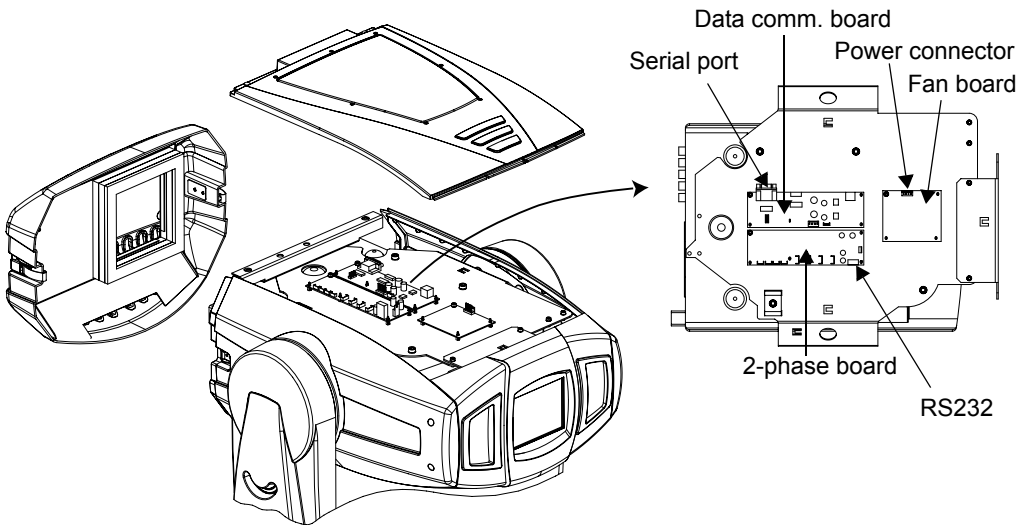

Figure 5-5 Driver board configurations



Caution: The fixture will not function correctly if addressing screws are missing from driver boards. Figure 5-5 identifies screw locations on each board.

When changing a board, align the screw holes and standoffs to ensure correct orientation in the fixture.

Replacing 2-Phase Board

To replace the 2-phase driver board:

1. Disconnect power to the fixture and allow it to cool.
2. Unlatch the two rear latches and remove the rear bezel.

Figure 5-1 shows the location of the rear latches and rear bezel.

3. Use a 3 mm allen wrench to remove the addressing screws and star washers.
4. Position new board against module aligning the center top standoff. Place contact screw(s) in the appropriate position.

Note: When installing a replacement driver board on a module, always place a star washer between an address screw and the pad on the logic board to ensure good electrical contact.

5. Carefully replace the rear bezel, making sure to place (but do not force) the gasket (shown in Figure 5-6) over the lamp cover located on the back of the projector.

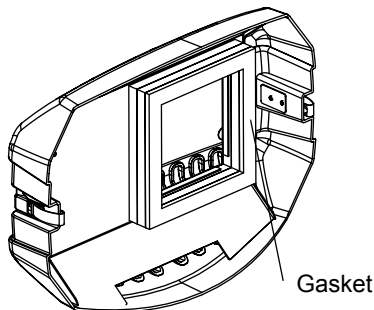

Figure 5-6 DL.1 Rear Gasket

Replacing 3-Phase or CPU Board

To replace the 3-phase driver board:

1. Disconnect power to the fixture. If the fixture has been operating, allow the fixture to cool before handling.
2. Facing the menu display with the fixture upright, remove the six M4 socket cap screws from the left end bracket as shown in Figure 5-7.

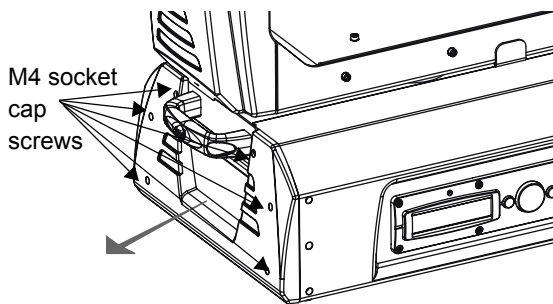

Figure 5-7 Accessing CPU and 3-phase boards.

3. Slide the side assembly out of the topbox. The CPU board is on the base and two 3-phase boards are on either side of the assembly.
4. Use a 3 mm allen wrench to remove the addressing screws and star washers, (see Figure 5-8 on page 5-11 for addressing screw location).
5. Position the new board against module aligning the center top standoff. Place contact screw(s) in the appropriate position.

Note: When installing a replacement driver board on a module, always place a star washer between an address screw and the pad on the logic board to ensure good electrical contact.



Caution: The fixture will not function correctly if contact screws are missing from boards.

6. Replace the side assembly. Make sure you align the assembly properly when inserting; damage to the fixture can result from improper alignment.
7. Replace the six M4 socket caps that secure the side assembly to the fixture.

Note: Filter calibration values are stored in non-volatile memory on the CPU board. After replacing the CPU board you will need to recalibrate the filter system, see “Recalibrating the Filter System:” on page 5-3.

General Troubleshooting

This section discusses troubleshooting LED states and general troubleshooting suggestions.

LED States

LEDs located on DL.1 fixture boards indicate how the unit is functioning. Table 5-1 lists LED States, and problems they may indicate. For details on locating board LEDs, see Figure 5-8 on page 5-11.

Table 5-1 LED States

LED Location	LED #	State	Problem?	Description
2-phase Board	LD1	Steady Green	No	S3 (dimming iris) sensor open
		Steady Yellow	No	S3 (dimming iris) sensor closed
		Blinking Red	No	Board is initializing
	LD2	Infinitely Blinking Red	Yes	Board not receiving data
		Steady red	Yes	Board not receiving data
	LD3	Blinking Red and Green	Yes	Addressing screw(s) missing from board
		OFF	Yes	Board not receiving power
		Steady Green	No	Receiving proper voltage
	LD4	Blinking Dim Green	No	Receiving data
		Dim Green	Yes	Board not receiving data
		OFF	Yes	Board not receiving power
		Steady Green	No	Receiving proper voltage

Table 5-1 LED States

LED Location	LED #	State	Problem?	Description
3-phase Boards	LD1	Steady Green	No	Board receiving proper voltage
		Dim Green	Yes	Board not receiving data
		OFF	Yes	Board not receiving power
	LD2	Blinking Red	Yes	Board not programmed
	LD3	Steady Green	No	Board programmed properly
		Blinking Red	Yes	Board not programmed
Fan Board	LD1	Blinking Green	No	Board receiving signals from CPU
		Steady Red	Yes	Board not receiving data
	LD2	Blinking Green	No	Board receiving
		Steady Green	Yes	Error while receiving
		Blinking Red	No	Board is transmitting
		Steady Red	Yes	Error while transmitting
CPU Board	LD1	Steady Orange	No	Receiving information from 2 & 3 phase boards
	LD1	Flickering	Yes	Not receiving information from 2 & 3 phase boards
	LD2	Steady Green	No	Board receiving proper voltage
		OFF	Yes	Board not receiving power
	LD3	Steady Red	No	Currently not used
	LD4	Steady Green	No	Receiving data
OFF		Yes	Not receiving data	
On front of fixture		Steady Red	No	Transmitting DMX
		Steady Green	No	Receiving DMX data
		Off	Yes, if data is applied	DMX data is not being received from the CPU Board
RS-232 Board	LD1	Steady Green	No	CPU operating properly
		Blinking Red	Yes, if after homing	RS-232 Board not found
	LD2	Blinking Green	No	Receiving DMX Data
		Blinking Red	No	Transmitting DMX Data

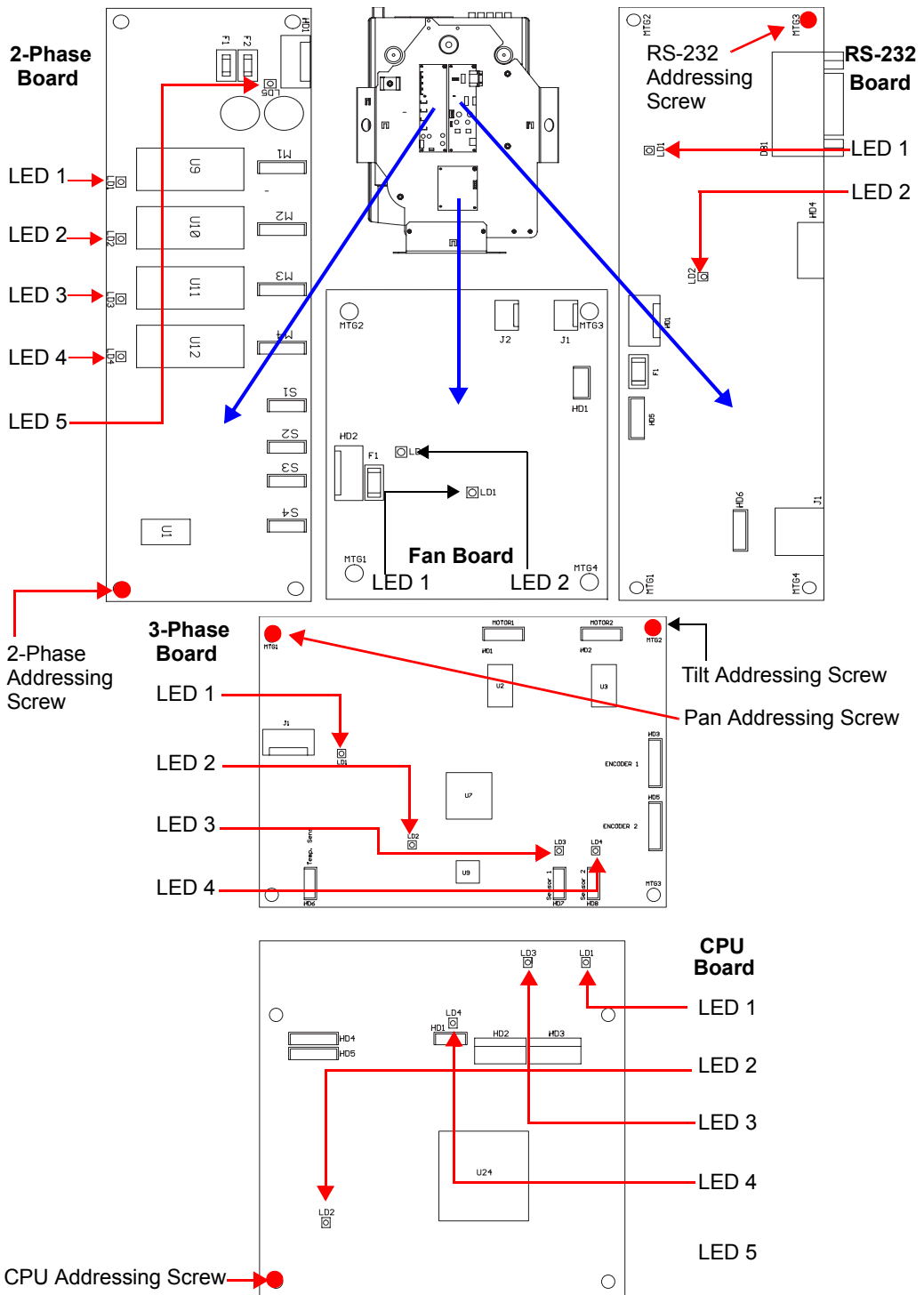

5

Figure 5-8 Addressing screw and LED locations.

General Troubleshooting Suggestions

Table 5-2 shows general troubleshooting suggestions:

Table 5-2 DL.1 Troubleshooting Suggestions

Problem	Solution
The fixture won't power on	<ol style="list-style-type: none"> 1. Verify fixture is plugged in to an appropriately-rated power source (power ratings are shown on page 1-4). 2. Verify the power switch is in the ON position. 3. Check the fuse (page 5-5). 4. Check power cord wiring (page page 2-1).
The fixture powers on but no image	<ol style="list-style-type: none"> 1. Make sure a video input is physically attached to the input you selected, and that the video feed is active. 2. Is the dimming iris closed? (If so, check the setting for DMX channel 10—Control—which usually shuts the dimming iris. See page 4-4.) 3. Did you recently change inputs? About 10 seconds are required for an input change to take effect. However, you might have selected an invalid input using projector controls. 4. Set the projector back to its default settings as shown on page 3-9. Or use the DMX protocol to exit the projector menu system (see page 4-4).
Image is blurry, out of focus, or colors are unnatural	<ol style="list-style-type: none"> 1. Check the housing filter (see page 5-2). 2. Is the DL.1 mounted less than 1.4 meters to an object? If so, move the DL.1 farther away to enable it to focus properly. 3. Make sure the DL.1 is not operating near fog machines, hazers, or mineral oil hazers (see page 2-4). 4. Clean the front window (see page 5-6). 5. Check the lamp (see the projector manual shipped with the DL.1). 6. If you're using the projector's on-screen programming system, you can override zoom and focus using the menu system (see page 3-10).
Projector behaves erratically or won't respond to DMX control	<ol style="list-style-type: none"> 1. To control the internal projector with the DMX protocol, you must first enable DMX (see page 3-10). 2. If you're using DMX to control the projector using its native menu system, make sure you send a safe command after each button command; otherwise, it's analogous to pressing a button on the projector menu system and not releasing it (see page 4-4).

Appendix A:

Safety Information

Warning: For Continued Protection Against Fire

1. This equipment for connection to branch circuit having a maximum overload protection of 20 A.

Warning: For Continued Protection Against Electric Shock

1. If this equipment was received without a line cord plug, attach the appropriate line cord plug according to the following code:
 - brown–live
 - blue–neutral
 - green/yellow–earth
2. As the colours of the cores in the mains lead of this equipment may not correspond with the coloured markings identifying the terminals in your plug, proceed as follows:
 - the core which is coloured green and yellow must be connected to the terminal in the plug which is marked with the letter E or by the earth symbol , or coloured green or green and yellow.
 - the core which is coloured blue must be connected to the terminal which is marked with the letter N or coloured black.
 - the core which is coloured brown must be connected to the terminal which is marked with the letter L or coloured red.
3. Class I equipment. This equipment must be earthed.
4. Equipment suitable for dry locations only. Do not expose this equipment to rain or moisture.
5. Refer servicing to qualified personnel; no user serviceable parts inside.



Appendice A

Importantes Informations Sur La Sécurité

Mise En Garde: Pour Une Protection Permanente Contre Les Incendies

1. Cet appareil de connection au circuit comporte une protection contre les surcharges de 20 A.

Mise En Garde: Pour Une Protection Permanente Contre Les Chocs Électriques

2. Si cet équipement est livré sans prise de cable, veuillez connecter la prise de cable correcte selon le code suivant:
 - marron - phase
 - bleu - neutre
 - vert/jaune - terre
3. Débrancher le courant avant de changer les lampes ou d'effectuer des réparations.
4. Cet équipement doit être uniquement utilisé dans des endroits secs. Ne pas l'exposer à la pluie ou l'humidité.
5. À l'intérieur de l'équipement il n'y a pas de pièces remplaçables par l' utilisateur. Confiez l'entretien à un personnel qualifié.
6. Equipement de Classe I. Cet équipement doit être mis à la terre.

Anhang A

Wichtige Hinweise Für Ihre Sicherheit

Warnung: Zum Schutz Vor Brandgefahr

1. Dieses Gerät darf nur an eine Zweigleitung mit einem Überlastungsschutz von höchstens 20 A angeschlossen werden.

Warnung: Zum Schutz Gegen Gefährliche Körperströme

1. Wenn dieses Gerät ohne einen Netzkabelstecker erhalten wurde, ist der entsprechende Netzkabelstecker entsprechend dem folgenden Code anzubringen:
 - Braun - Unter Spannung stehend
 - Blau - Neutral
 - Grün/Gelb - Erde
2. Vor dem Austauschen von Lampen oder vor Wartungsarbeiten stets den Netzstecker ziehen.
3. Diese Geräte sind nur zum Einbau in trockenen Lagen bestimmt und müssen vor Regen und Feuchtigkeit geschützt werden.
4. Servicearbeiten sollten nur von Fachpersonal ausgeführt werden. Das Gerät enthält keine wartungsbedürftigen Teile.
5. Dieses Gerät gehört zur Klasse I. Dieses Gerät muß geerdet werden.



Apéndice A

Información Importante De Seguridad

Advertencia: Para Protección Continua Contra Incendios

1. Este equipo debe conectarse a un circuito que tenga una protección máxima contra una sobrecargas de 20 A.

Advertencia: Para La Protección Continua Contra Electrocuiones

1. Si se recibió este equipo sin el conector de alimentacion, monte usted el conector correcto según la clave siguiente:
 - moreno - vivo
 - azul - neutral
 - verde/amarillo - tierra
2. Desconecte el suministro de energía antes de cambiar lámparas o prestar servicio de reparación.
3. Este equipo esta disenado para usarse en lugares secos no lo exponga a la lluvia o humedad.
4. Derive el servicio de reparación de este equipo al personal calificado. El interior no contiene repuestos que puedan ser reparados por el usuario.
5. Equipo de Clase I. Este equipo debe conectarse a tierra.

Appendice A

Importanti Informazioni Di Sicurezza

Avvertenza: Per Prevenire Incendi

1. Questa apparecchiatura e' da collegarsi ad un circuito con una protezione da sovraccarico massima di 20 ampere.



Avvertenza: Per Prevenire Le Scosse Elettriche

1. Da non montare sopra una superficie infiammabile.
2. Mantenere l' apparecchio a un minimo di 1.0 metri (3.28 piedi) di distanza dai materiali combustibili.
3. Sostituire i fusibili usando soltanto quelli del tipo e della taratura adatta.
4. Mantenere una distanza minima di 1.0 metri (3.28 piedi) dagli oggetti accesi.
5. Questa apparecchiatura e' da collegarsi ad un circuito con una protezione da sovraccarico massima di 20 ampere.



Vigtig Sikkerhedsinformation

Advarsel: Beskyttelse mod elektrisk chock.

VIGTIGT! LEDEREN MED GUL/GROEN ISOLATION MAA KUN TILSLUTTETES
KLEMME MAERKET  ELLER .

Appendix B:

MSpeed Conversion Table

The following table lists the MSpeed (motor) movement times and their corresponding DMX controller values. If you have a numeric-type controller, use the Value Decimal (dec.) column. If you have a fader-type controller, use the Value Percentage (%) column. If your controller allows you to program hex values, use the Value (hex) column.

Time (sec.)	Value (dec.)	Value (%)	Value (hex)
0.15	255	100	FF
0.15	254	100	FE
0.17	253	99	FD
0.19	252	99	FC
0.21	251	98	FB
0.25	250	98	FA
0.29	249	98	F9
0.35	248	97	F8
0.41	247	97	F7
0.47	246	96	F6
0.55	245	96	F5
0.63	244	96	F4
0.73	243	95	F3
0.83	242	95	F2
0.94	241	95	F1
1.05	240	94	F0
1.18	239	94	EF
1.31	238	93	EE
1.45	237	93	ED
1.60	236	93	EC
1.75	235	92	EB
1.92	234	92	EA
2.09	233	91	E9
2.27	232	91	E8
2.46	231	91	E7
2.66	230	90	E6
2.86	229	90	E5

Time (sec.)	Value (dec.)	Value (%)	Value (hex)
3.07	228	89	E4h
3.29	227	89	E3
3.52	226	89	E2
3.76	225	88	E1
4.00	224	88	E0
4.25	223	87	DF
4.52	222	87	DE
4.78	221	87	DD
5.06	220	86	DC
5.34	219	86	DB
5.64	218	85	DA
5.94	217	85	D9
6.25	216	85	D8
6.56	215	84	D7
6.89	214	84	D6
7.22	213	84	D5
7.56	212	83	D4
7.91	211	83	D3
8.27	210	82	D2
8.63	209	82	D1
9.00	208	82	D0
9.39	207	81	CF
9.77	206	81	CE
10.17	205	80	CD
10.58	204	80	CC
10.99	203	80	CB
11.41	202	79	CA

Time (sec.)	Value (dec.)	Value (%)	Value (hex)
11.84	201	79	C9
12.28	200	78	C8
12.72	199	78	C7
13.17	198	78	C6
13.63	197	77	C5
14.10	196	77	C4
14.58	195	76	C3
15.07	194	76	C2
15.56	193	76	C1
16.06	192	75	C0
16.57	191	75	BF
17.09	190	75	BE
17.61	189	74	BD
18.14	188	74	BC
18.68	187	73	BB
19.23	186	73	BA
19.79	185	73	B9
20.36	184	72	B8
20.93	183	72	B7
21.51	182	71	B6
22.10	181	71	B5
22.70	180	71	B4
23.30	179	70	B3
23.92	178	70	B2
24.54	177	69	B1
25.17	176	69	B0
25.80	175	69	AF

B

Time (sec.)	Value (dec.)	Value (%)	Value (hex)	Time (sec.)	Value (dec.)	Value (%)	Value (hex)	Time (sec.)	Value (dec.)	Value (%)	Value (hex)
26.45	174	68	AE	55.96v	137	54	89	97.70	99	39	63
27.10	173	68	AD	56.91	136	53	88	98.95	98	38	62
27.76	172	67	AC	57.87	135	53	87	100.22	97	38	61
28.43	171	67	AB	58.84	134	53	86	101.49	96	38	60
29.11	170	67	AA	59.81	133	52	85	102.77	95	37	5F
29.80	169	66	A9	60.79	132	52	84	104.05	94	37	5E
30.49	168	66	A8	61.78	131	51	83	105.35	93	36	5D
31.19	167	65	A7	62.78	130	51	82	106.65	92	36	5C
31.90	166	65	A6	63.79	129	51	81	107.96	91	36	5B
32.62	165	65	A5	64.80	128	50	80	109.28	90	35	5A
33.34	164	64	A4	65.82	127	50	7F	110.61	89	35	59
34.08	163	64	A3	66.85	126	49	7E	111.94	88	35	58
34.82	162	64	A2	67.89	125	49	7D	113.28	87	34	57
35.57	161	63	A1	68.94	124	49	7C	114.63	86	34	56
36.33	160	63	A0	69.99	123	48	7B	115.99	85	33	55
37.09	159	62	9F	71.05	122	48	7A	117.36	84	33	54
37.87	158	62	9E	72.13	121	47	79	118.73	83	33	53
38.65	157	62	9D	73.20	120	47	78	120.12	82	32	52
39.44	156	61	9C	74.29	119	47	77	121.5v	81	32	51
39.44v	156	61	9C	75.38	118	46	76	122.91	80	31	50
40.23	155	61	9B	76.49	117	46	75	124.31	79	31	4F
41.04	154	60	9A	77.60	116	45	74	125.73	78	31	4E
41.85	153	60	99	78.71	115	45	73	127.15	77	30	4D
42.68	152	60	98	79.84	114	45	72	128.58	76	30	4C
43.50	151	59	97	80.98	113	44	71	130.02	75	29	4B
44.34	150	59	96	82.12	112	44	70	134.39	72	28	48
45.19	149	58	95	83.27	111	44	6F	135.86	71	28	47
46.04	148	58	94	84.43	110	43	6E	137.34	70	27	46
46.90	147	58	93	85.59	109	43	6D	138.82	69	27	45
47.77	146	57	92	86.77	108	42	6C	140.32	68	27	44
48.65	145	57	91	87.95	107	42	6B	141.82	67	26	43
49.54	144	56	90	89.14	106	42	6A	143.33	66	26	42
50.43	143	56	8F	90.34	105	41	69	144.85	65	25	41
51.33	142	56	8E	91.55	104	41	68	146.38	64	25	40
52.24	141	55	8D	92.76	103	40	67	147.92	63	25	3F
53.16	140	55	8C	93.98	102	40	66	149.46	62	24	3E
54.09	139	55	8h	95.21	101	40	65	151.01	61	24	3D
55.02	138	54	8A	96.45	100	39	64	152.57	60	24	3C

Time (sec.)	Value (dec.)	Value (%)	Value (hex)
154.14	59	23	3B
155.71	58	23	3A
157.30	57	22	39
158.89	56	22	38
160.49	55	22	37
162.09	54	21	36
163.71	53	21	35
165.33	52	20	34
166.96	51	20	33
168.60	50	20	32
170.25	49	19	31
171.91	48	19	30
173.57	47	18	2F
175.24	46	18	2E
176.92	45	18	2D
178.61	44	17	2C
180.30	43	17	2B
182.01	42	16	2A
183.72	41	16	29
185.44	40	16	28
187.17	39	15	27
188.90	38	15	26
190.65	37	15	25
192.40	36	14	24
194.16	35	14	23
195.92	34	13	22
197.70	33	13	21
199.48	32	13	20
201.28	31	12	1F
203.08	30	12	1E
204.88	29	11	1D
206.70	28	11	1C
208.52	27	11	1B
210.36	26	10	1A
212.19	25	10	19
214.04	24	9	18
215.90	23	9	17
217.76	22	9	16

Time (sec.)	Value (dec.)	Value (%)	Value (hex)
219.63	21	8	15
221.51	20	8	14
223.40	19	7	13
225.30	18	7	12
227.20	17	7	11
229.11	16	6	10
231.03	15	6	0F
232.96	14	5	0E
234.90	13	5	0D
236.84	12	5	0C
238.79	11	4	0B
240.75	10	4	0A
242.72	9	4	09
244.70	8	3	08
246.68	7	3	07
248.68	6	2	06
250.68	5	2	05
246.68	7	3	07
248.68	6	2	06
250.68	5	2	05
252.68	4	2	04

B

